

No. 3 1978

issued quarterly

Technical Review

To Advance Techniques in Acoustical, Electrical and Mechanical Measurement

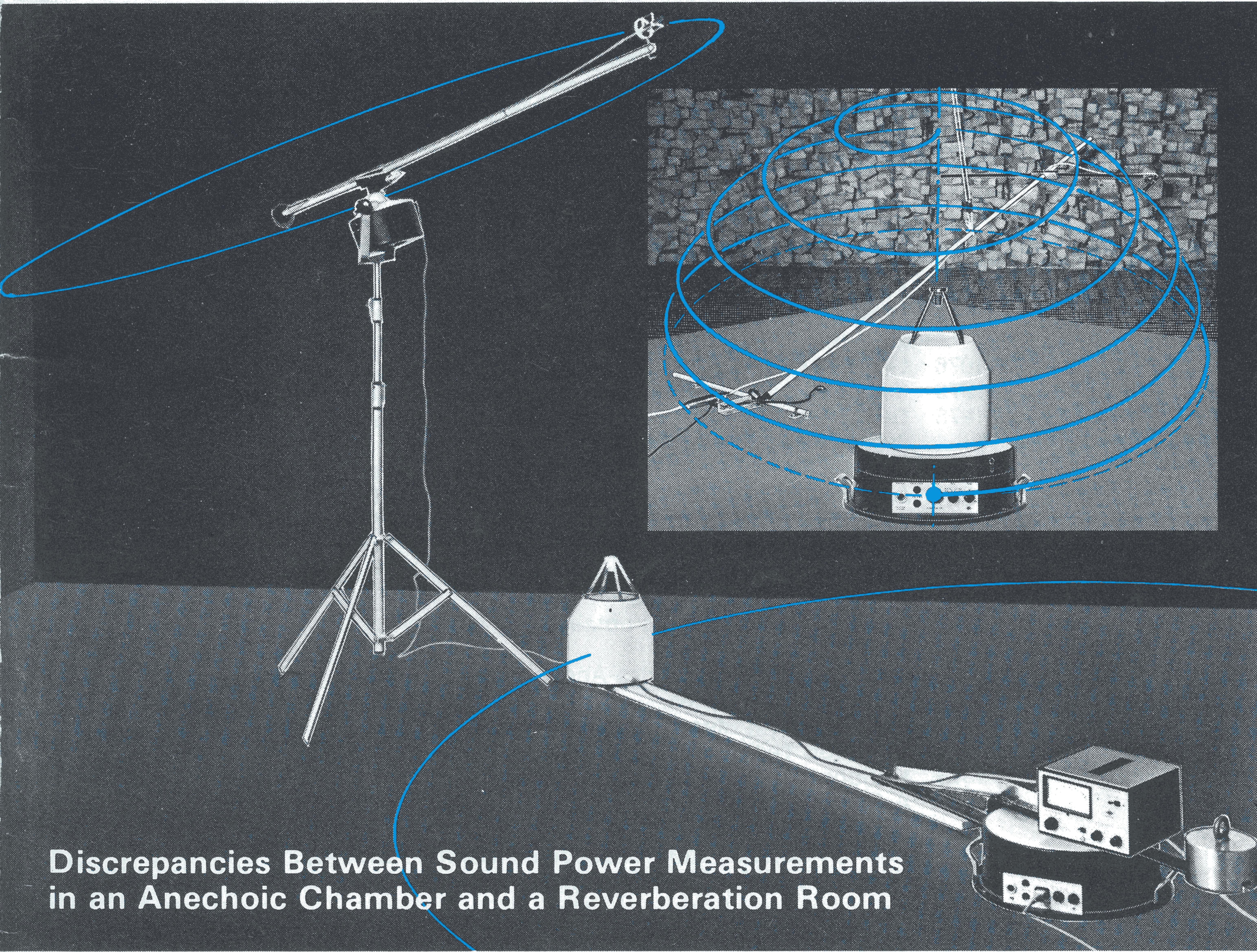

**Discrepancies Between Sound Power Measurements
in an Anechoic Chamber and a Reverberation Room**

Brüel & Kjær

**PREVIOUSLY ISSUED NUMBERS OF
BRÜEL & KJÆR TECHNICAL REVIEW**

- 2-1978 The Application of the Narrow Band Spectrum Analyzer Type 2031 to the Analysis of Transient and Cyclic Phenomena.
Measurement of Effective Bandwidth of Filters.
- 1-1978 Digital Filters and FFT Technique in Real-time Analysis.
- 4-1977 General Accuracy of Sound Level Meter Measurements.
Low Impedance Microphone Calibrator and its Advantages.
- 3-1977 Condenser Microphones used as Sound Sources.
- 2-1977 Automated Measurements of Reverberation Time using the Digital Frequency Analyzer Type 2131.
Measurement of Elastic Modulus and Loss Factor of PVC at High Frequencies.
- 1-1977 Digital Filters in Acoustic Analysis Systems.
An Objective Comparison of Analog and Digital Methods of Real-Time Frequency Analysis.
- 4-1976 An Easy and Accurate Method of Sound Power Measurements.
Measurement of Sound Absorption of rooms using a Reference Sound Source.
- 3-1976 Registration of Voice Quality.
Acoustic Response Measurements and Standards for Motion-Picture Theatres.
- 2-1976 Free-Field Response of Sound Level Meters.
High Frequency Testing of Gramophone Cartridges using an Accelerometer.
- 1-1976 Do We Measure Damaging Noise Correctly?
- 4-1975 On the Measurement of Frequency Response Functions.
- 3-1975 On the Averaging Time of RMS Measurements (continuation).
- 2-1975 On the Averaging Time of RMS Measurements
Averaging Time of Level Recorder Type 2306 and "Fast" and "Slow" Response of Level Recorders 2305/06/07
- 1-1975 Problems in Telephone Measurements.
Proposals for the Measurement of Loudness Ratings of Operators' Headsets.
Comparison of Results obtained by Subjective Measuring Methods.
Repeatabilities in Electro-Acoustic Measurements on Telephone Capsules.
Stable Subset Measurements with the 73 D
Vibration Testing of Telephone Equipment.
- 4-1974 Underwater Impulse Measurements.
A Comparison of ISO and OSHA Noise Dose Measurements.
Sound Radiation from Loudspeaker System with the Symmetry of the Platonic Solids.

(Continued on cover page 3)

TECHNICAL REVIEW

No.3—1978

Contents

The Enigma of Sound Power Measurements at Low Frequencies by P.V. Brüel	3
---	---

The Enigma of Sound Power Measurements at Low Frequencies

by

Per V. Brüel, D.Sc.

ABSTRACT

The possible reasons for the systematic differences obtained at low frequencies when sound power is determined in a free-field and a reverberation room have been investigated. They are 1) the influence of reverberation room impedance on the sound power output of a source 2) spacing between eigenmodes of the room at low frequencies and 3) determination of reverberation time from the decay curves. It is shown that better agreement between the two methods is obtained when the reverberation time is determined from the early decay rate than when the slope between -5 and -35 dB is used, as suggested by ISO Standards. As this is normally difficult to carry out using conventional instruments, it is recommended that comparison measurements be carried out in a reverberation room using a calibrated reference sound source whereby the above sources of error are minimised.

SOMMAIRE

On a cherché les raisons possibles des différences systématiques observées lors de mesures de puissance acoustique effectuées aux basses fréquences en champ libre ou en chambre réverbérante. Ceci est dû à 1) l'influence de l'impédance de la chambre réverbérante sur la puissance acoustique de sortie de la source 2) l'espacement des modes propres de la chambre aux fréquences basses 3) la détermination du temps de réverbération à partir des courbes d'amortissement. On montre que l'accord entre les deux méthodes sera meilleur si le temps de réverbération est déterminé à partir de la pente initiale plutôt qu'à partir de la pente entre -5 et -35 dB, comme le proposent les normes ISO. Cependant c'est assez difficile à réaliser avec les appareils habituels, aussi est-il recommandé d'effectuer des mesures comparatives en chambre réverbérante en utilisant une source sonore de référence étalonée, réduisant ainsi les causes d'erreur précédemment citées.

ZUSAMMENFASSUNG

Es wurden die möglichen Gründe für die systematischen Unterschiede, die bei Messungen der Schalleistung im tieffrequenten Bereich im Freifeld und im Nachhallraum auftreten, untersucht. Diese sind 1) der Einfluß der akustischen Impedanz des Nachhallraums auf den Schalleistungsausgang der Quelle 2) der Abstand der Eigenfrequenzen des Raums bei niedrigen Frequenzen und 3) die Ermittlung der Nachhallzeit aus den Schallabklingkurven. Es wird gezeigt, daß es eine bessere Übereinstimmung zwischen beiden Methoden gibt, wenn die Nachhallzeit aus dem Anfang der Schallabklingkurve bestimmt wird und nicht, wie in ISO-Standards empfohlen, zwischen -5 und -35 dB. Da dieses normalerweise mit konventionellen Geräten schwer zu bestimmen ist, wird empfohlen, Vergleichsmessungen mit einer kalibrierten Bezugsquelle im Nachhallraum durchzuführen. Hierbei werden die Fehlerquellen minimalisiert.

Introduction

When the transmission loss of a wall has to be determined, it is necessary to evaluate the total absorption of the receiving room. This is normally determined indirectly from reverberation time measurements and knowledge of the room volume, as recommended by ISO Standards 140 Parts III and IV. To simplify determination of the absorption in the room, an attempt was made three years ago to replace reverberation time measurements by measurement of the sound pressure level in the receiving room when it was excited by a calibrated reference sound power source. To our disappointment the results obtained by the two methods showed poor agreement at low frequencies.

Fig.1a shows a conventional instrumentation set-up for these measurements, while Fig.1b shows a simplified arrangement using portable instruments. The Sound Reduction Index R (transmission loss) is determined from the equation

$$R = L_1 - L_2 + 10 \log \left(\frac{S}{A_2} \right) \quad \text{dB}$$

where

- L_1 = mean sound pressure level in the source room
- L_2 = mean sound pressure level in the receiving room
- S = area of the wall specimen
- A_2 = equivalent absorption of the receiving room.

For both the measurement set-ups shown in Fig.1 the equivalent absorption of the receiving room is determined from the equation

$$A_2 = \frac{0,163 V_2}{T_2}$$

where V_2 is the volume of the receiving room and T_2 is the reverberation time.

The absorption of the receiving room was determined using both the reverberation time measurements as well as the reference sound power source as it was required anyway for exciting the source room. The re-

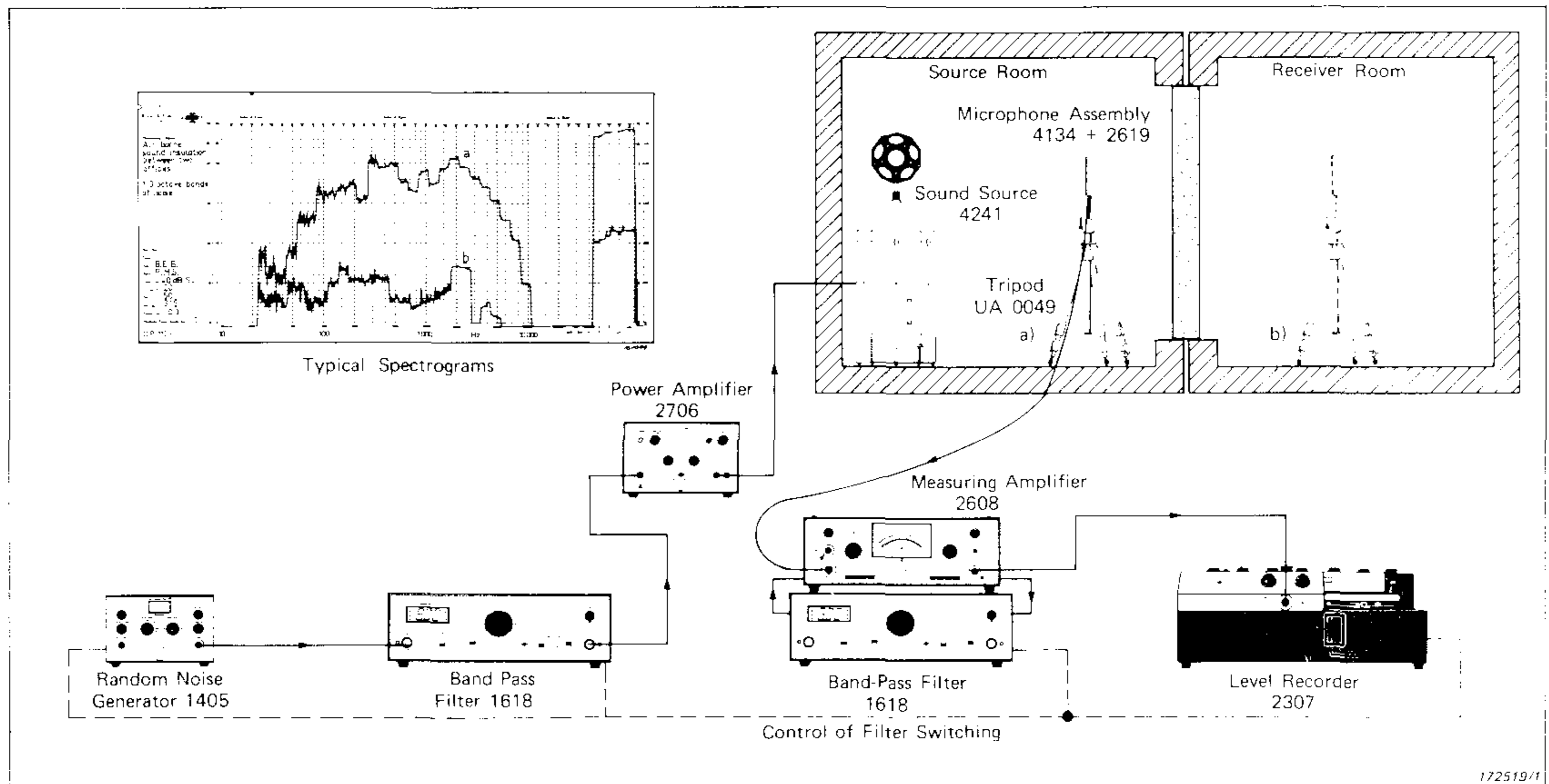

a)

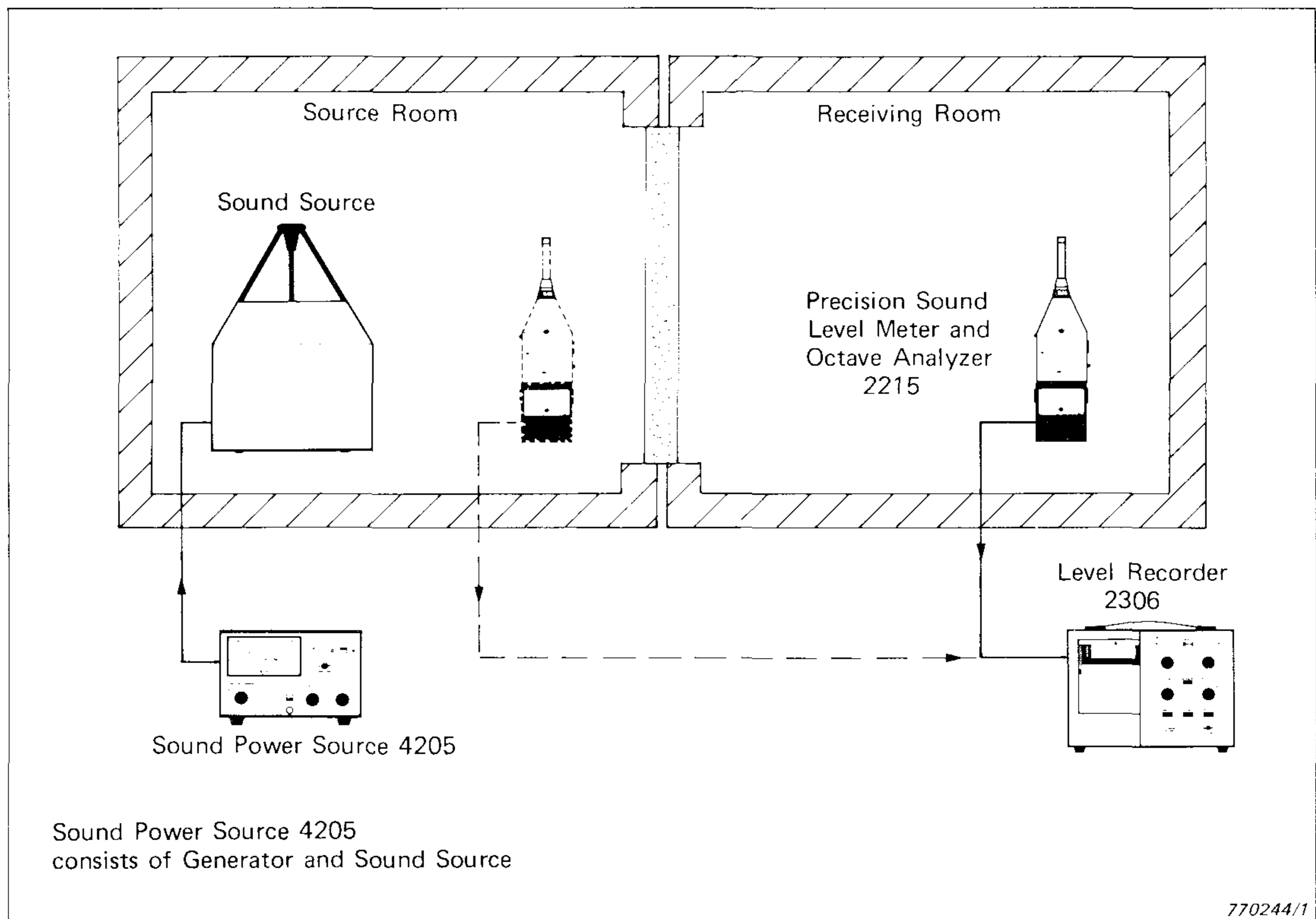

b)

Fig.1. Instrumentation set-ups for measurement of sound reduction index (transmission loss)

a) Conventional instruments

b) Simplified instruments

sults revealed that the absorption values obtained using the reverberation time method were lower (and thus the transmission loss values calculated were higher, as can be seen from the equation for R) than those obtained using the sound power source. The deviations were barely noticeable at 500 Hz, but increased rapidly for lower frequencies where the absorption obtained using the latter method could be twice as high at 100 Hz. At that time it was not possible to give a plausible explanation for the discrepancy. However it was known that the walls in practice did not isolate as well as the measurements predicted.

When determining the sound power emitted by a source in a reverberation room it is again necessary to determine the absorption of the room through reverberation time measurements. However, when the sound power of the same source is determined in the free-field and the results compared, the same enigmatical discrepancy arises at low frequencies. This led to the suspicion on the accuracy of reverberation time *determination* from the decay curves and its consequences on sound power measurements which have therefore been investigated in detail in the following.

Sound Power

ISO has recently issued a series of standards for the measurement of sound power,[1]. Two principally different methods are described: one is a free-field measurement which can be carried out in open air or in an anechoic room while the other involves measurement in a diffuse field which can be achieved in a reverberation chamber. In an anechoic room all the boundaries are highly absorbent and the acoustic free-field region extends very nearly to the boundaries. In a reverberation chamber all boundaries are relatively hard and the reverberant field extends over nearly the entire room with the exception of a small region around the sound source.

In the anechoic room the sound power radiated can be determined by measuring the sound pressure level and the microphone distance from the sound source. For diffuse field measurements the sound power in the reverberation chamber can be determined either by using a reference sound source for comparison with the unknown source or it can be determined from knowing the size of the room and the reverberation time. However, knowledge of how the sound pressure decreases with distance from a sound source is important in order to be able to choose the correct microphone positions. The way in which the sound pressure

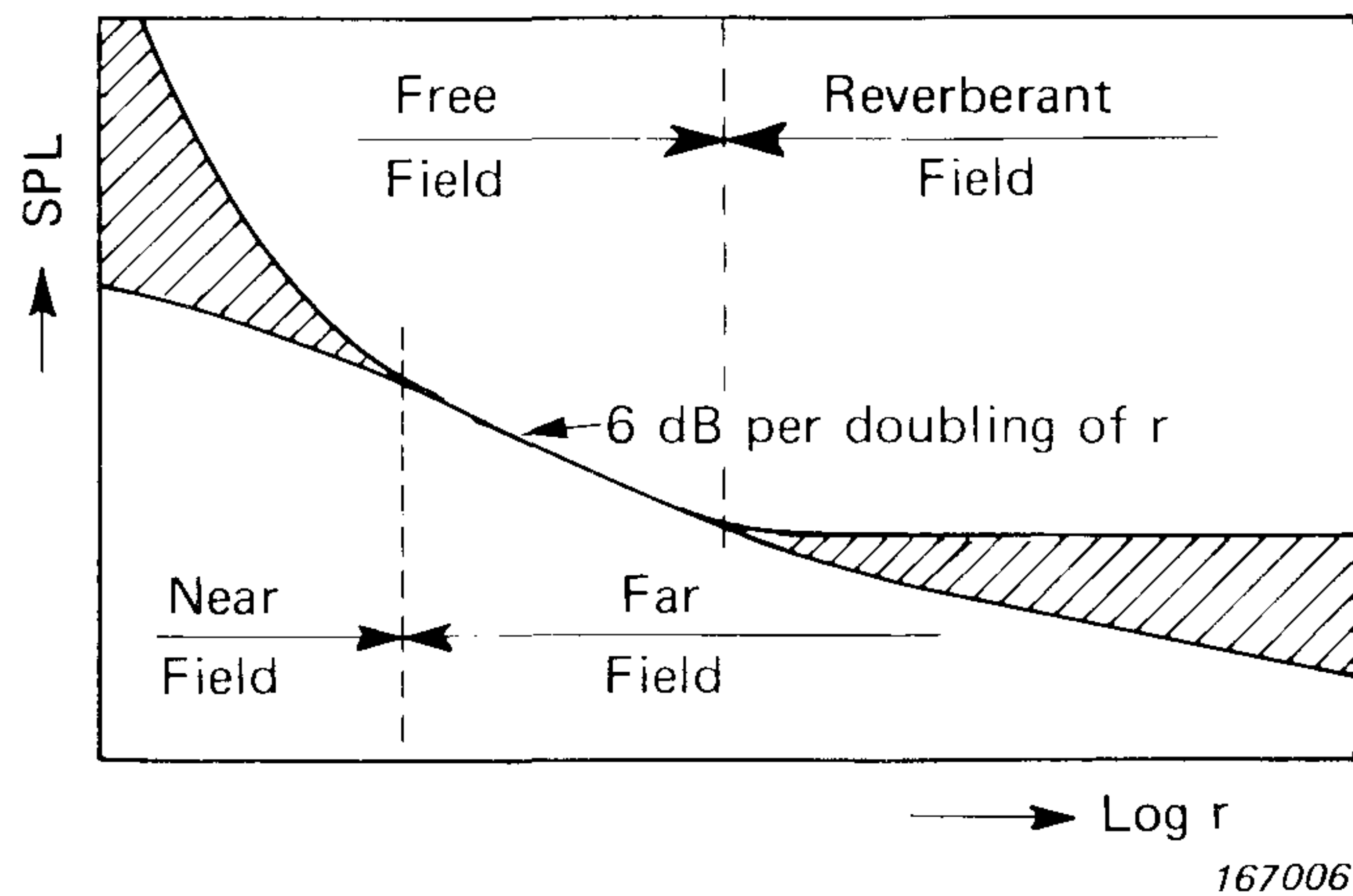

Fig.2. Variation of sound pressure level L_p in a room along a radius r from a noise source and the definitions of free- and reverberant field and the near- and far field. The shaded areas indicate regions where L_p fluctuates most with distance. In between the near- and reverberant fields, L_p decreases at the rate of 6 dB for each doubling of distance from the acoustic centre of the source

decreases with the distance and the related definitions are indicated in Fig.2.

There has however been a perplexing problem concerning the determination of sound power: in the reverberation chamber at low frequencies the sound power determined is lower than when determined in the free-field. Fig.3 shows the difference between an ILG sound source measured in the free-field and in a reverberation chamber. The figure has been reproduced from Beranek,[2], Table 6.1 where different values are given for free-field and diffuse-field calibration. However, no explanation has been offered for this intriguing discrepancy.

Literature survey carried out on sound power has also revealed further similar examples: Fig.4 shows some results obtained by Wells & Wiener [3] using another ILG reference source and a loudspeaker in both a free-field and reverberation chamber. Fig.4 also shows similar results obtained by Burger [4] et al. O. Kramář [5] has compared the power output from reference sound sources measured in a free-field with that measured in two reverberation chambers of 116 m^3 and 1035 m^3 respectively, Fig.4.

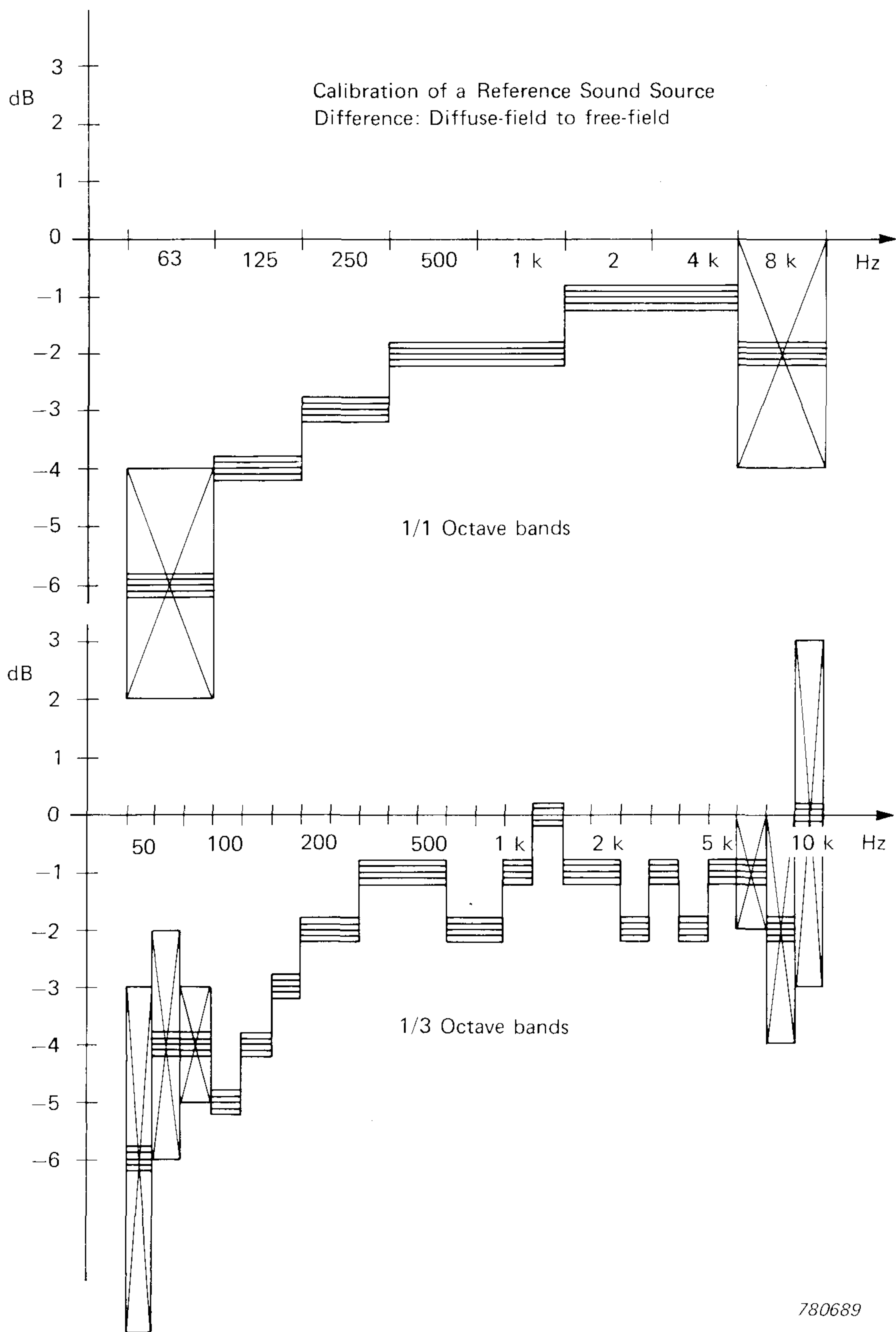

Fig.3. The sound power level of an ILG standard reference source measured in several reverberation chambers compared to the level obtained in free-field (From L.L. Beranek [2])

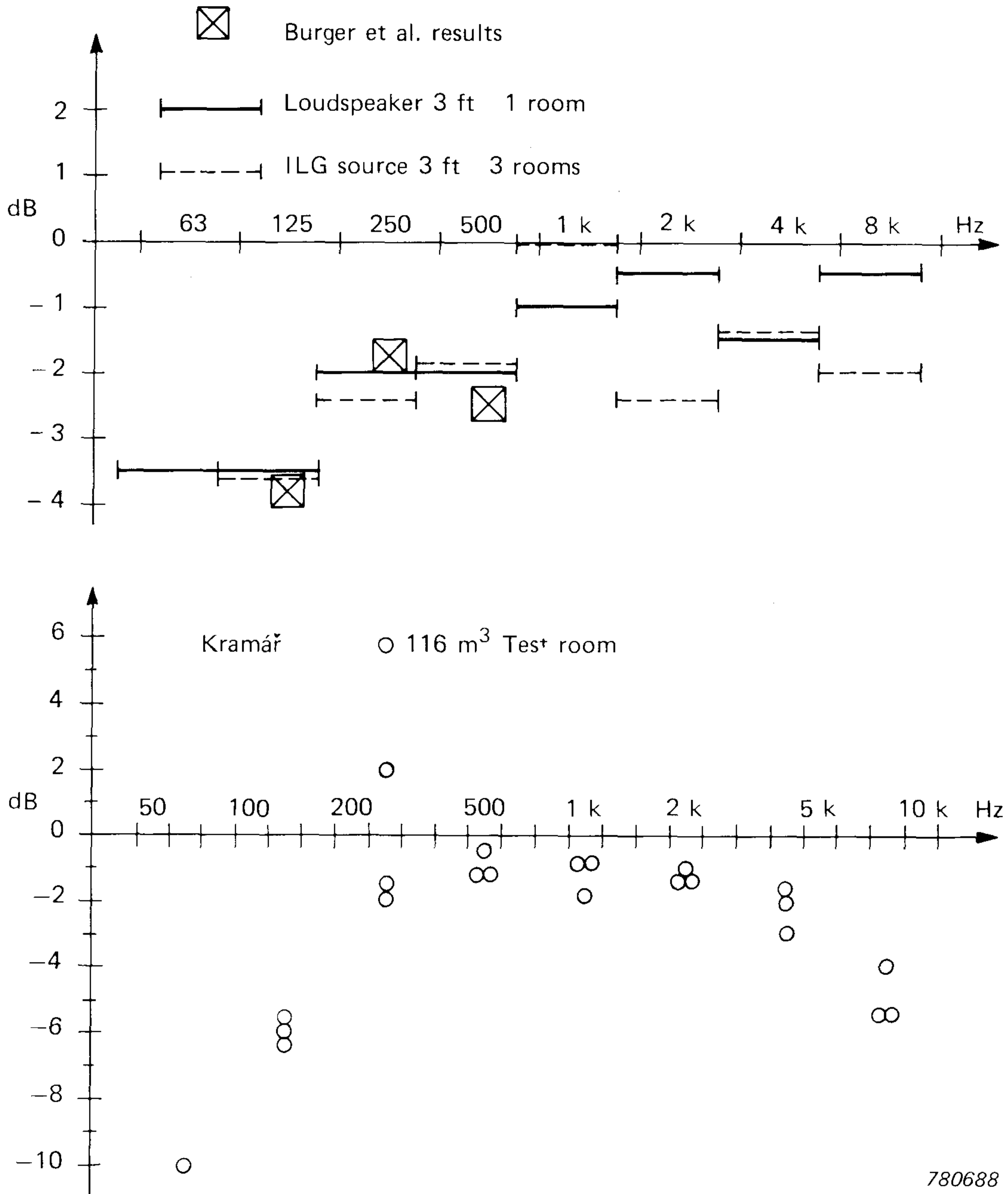

Fig.4. Sound power level of an ILG source and a loudspeaker measured in a reverberation chamber compared to the level obtained in free-field. (From Wells & Wiener and Burger et al). Below similar results from Kramář for an aerodynamic source

A detailed investigation has recently been made by P. Francois [6] and his main results are indicated in Fig.5. These measurements have been carried out with the utmost care and accuracy in several different laboratories using various sound sources. The so-called "Waterhouse" correction* has also been taken into account.

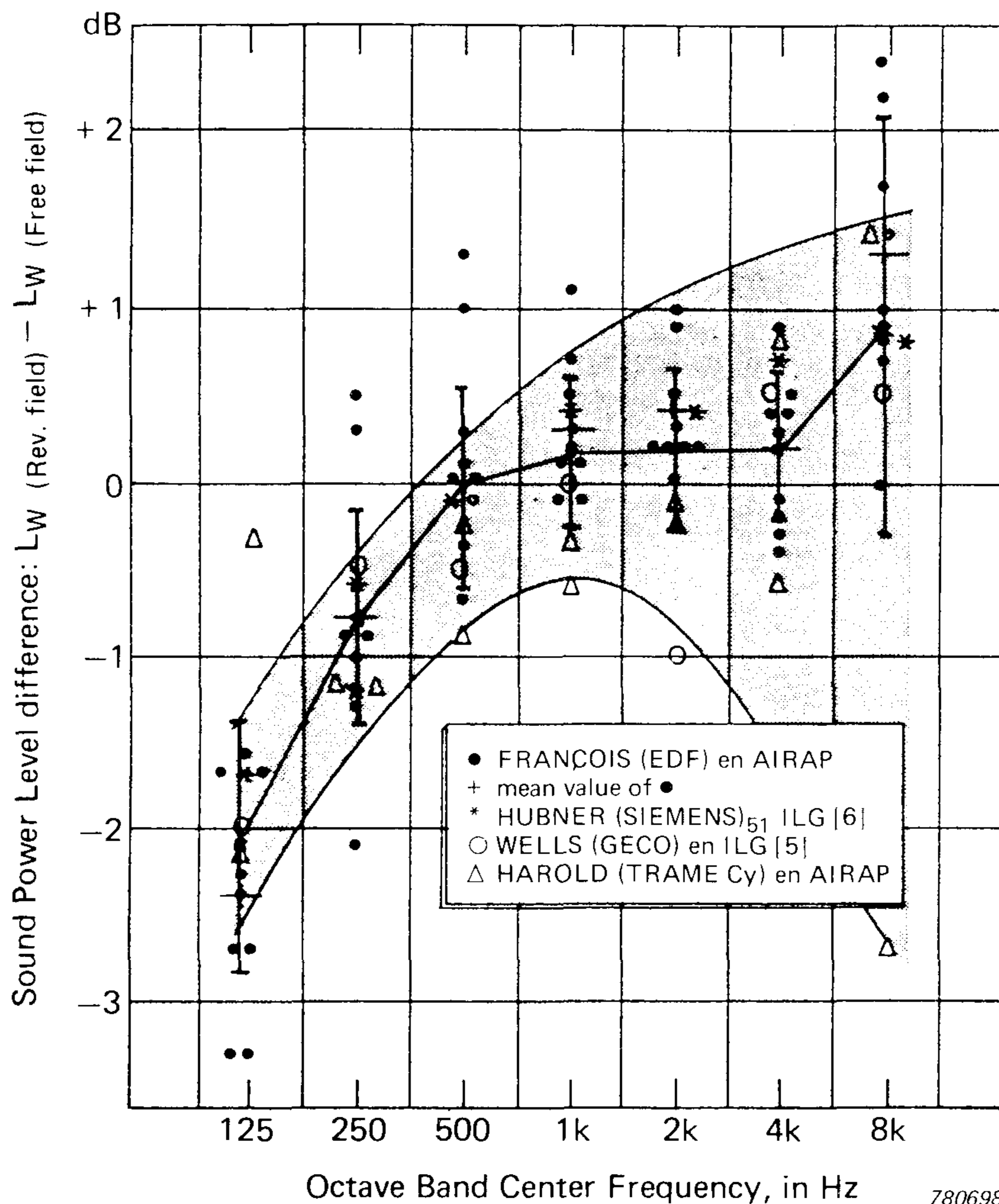

Fig.5. Systematic difference between reverberant and free-field determination of the sound power level of two reference sound sources measured in several laboratories (Francois [6])

* The "Waterhouse" correction has been incorporated to account for the sound pressure in the room being always higher near the reflecting walls than away from them. As the sound pressure in practice is always measured in the middle of the room the correction is necessary.

When examining the above results the conclusion one arrives at is that a systematic difference seems to prevail between the sound power radiated from sound sources when determined in a free-field and when determined in a diffuse-field at low frequencies (50-500 Hz). The most significant deviations are found at the lowest frequencies and apparently the values obtained using the diffuse field calibration are always lower than those obtained from the free-field calibration.

There are also deviations at higher frequencies but here the errors are not systematic when all the measurements referred to are compared. Nevertheless some authors [7] ascribe the reported differences between the two methods to measurement uncertainties of a systematic nature. With the use of very accurate measurement equipment available today it is possible by means of automatic systems using calculators to perform a large number of measurements. Hereby not only a reasonably accurate average value is obtained but also the uncertainties of the actual measurements are reduced significantly.

The object of this article has been to verify — on the basis of measurements carried out as accurately as possible — whether a specific sound source gives a systematic difference in sound power when determined in a free-field and in a reverberation chamber, and if that is the case to give a plausible explanation for the discrepancy.

Sound Sources

Two different reference sound sources were chosen as test specimens: one with a low internal acoustical impedance and the other with a high impedance. The B & K reference sound source Type 4204, Fig.6 has been constructed to give a constant wide band sound output. It is used as a reference source when other sound sources are to be compared.

Type 4204 consists of a centrifugal fan driven by an asynchronous motor where the sound is generated by vortices in the periphery of the rotor. It has a fairly poor acoustical efficiency for which reason there is little interaction between its generated noise and the electrical input power. The acoustical power output is independent of both temperature and humidity but directly proportional to the static pressure. The relatively low sound power is emitted from a large surface indicating a low internal impedance. The other sound source Type 4205 shown in Fig.6 generates the sound pressure via a loudspeaker and thus has a much higher internal impedance than type 4204. As will be shown later it is

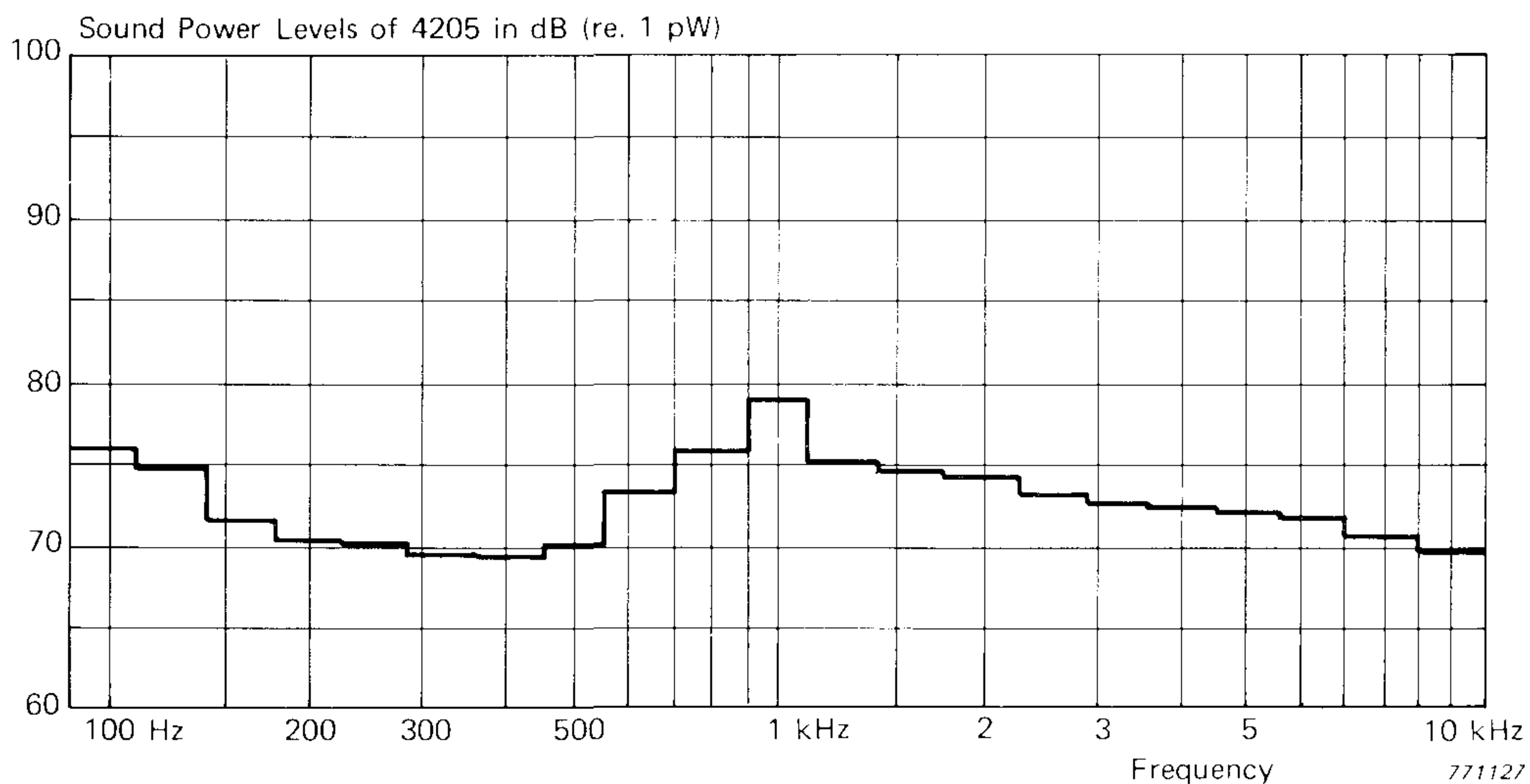
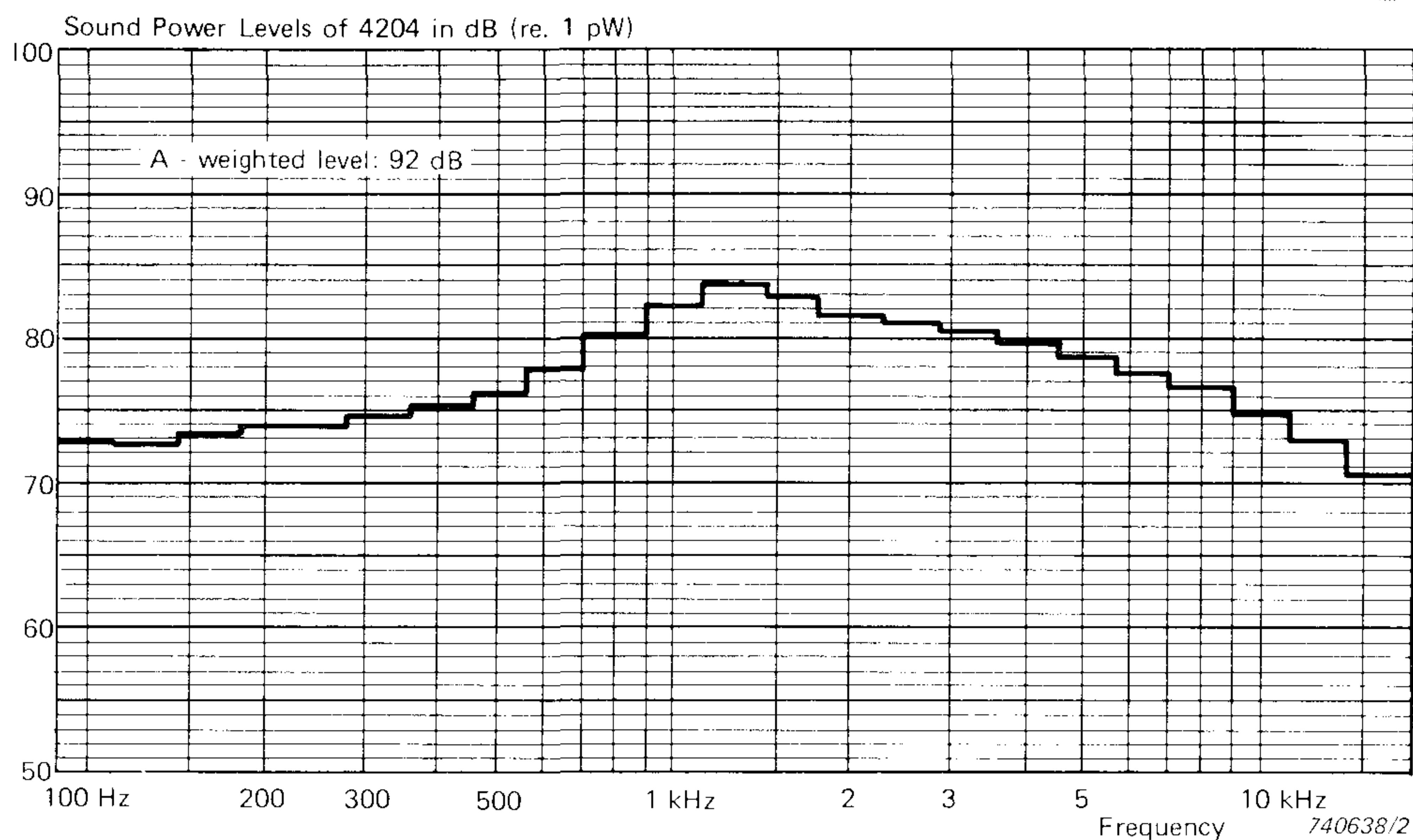

Fig. 6. The sound sources used as measuring objects. Left the Standard Reference Sound Source Type 4204, and right the Sound Power Source Type 4205 with amplifier. Below their typical power spectra

The sound power source Type 4205 has no long-term stability problems as its output in the near-field can be adjusted each time before the measurements, using a precision sound level meter. For this sound source, only short-term stability is of importance and at constant temperature no variation in its output power has been observed. To determine the stability of the 4205 indirectly, the standard deviation in the sound pressure level of 18 specimens were calculated for each octave band when the outputs of the sources were adjusted to a sound power level of 75 dB re. 1 pW. It can be seen from Table 1 that the standard deviation is of the order of 0,1 to 0,2 dB whereby this source can also be regarded as very stable.

Frequency	dB re 2×10^{-5} Pa	Standard Dev.
125 Hz	85,93	0,14
250 Hz	87,40	0,13
500 Hz	89,61	0,15
1 kHz	90,39	0,11
2 kHz	94,05	0,13
4 kHz	93,33	0,15
8 kHz	97,04	0,38
A-curve	93,02	0,22

780187

Table 1

Comparison Measurements

The power radiated from the two sound sources was determined in a free-field over a reflecting plane and in several reverberation chambers. Measurements were carried out in both octave and third octave bands, and microphone positions and their distances from the sound source and walls were chosen according to ISO Standards 3745 and 3741.

From the data obtained, it is possible to determine average values for each frequency band and also to determine the degree of uncertainty of the results. Some of the factors which cause the spread in the results and thus have to be taken account of are outlined below.

In an anechoic room some inaccuracies arise in the measurement of the sound pressure level which should be measured in the far-field and

not too close to the test object. The anechoic room should be sufficiently adequate also at the lower frequencies. Further the sound sources should be stable and emit the same power for all the measurements.

In the reverberation chamber we have not only the above-mentioned precautions to take care of, but also to ensure that the measurement is carried out in the reverberant field, that the reverberation time measurements are correct, and that the power radiated from the sound sources is relatively independent of the impedance in the room, as it is well known that the impedance in a reverberation chamber varies drastically from one position to another. All the measurements are carried out with the sound sources placed on a hard sound reflecting plane as recommended in the ISO Standards.

Free-Field Measurements

Fig.8 shows the instrumentation set-up used for free-field measurements in the anechoic chamber. The details of the method are described in an article by H. Larsen [8]. By scanning the microphone as shown in the figure, the sound pressure level is integrated for all angles of radiation ($0^\circ - 90^\circ$) and the mean value in each third-octave band can be obtained on the real-time analyzer for a single sweep of the microphone. Using this method considerable time can be saved, and an extraordinary measurement accuracy is achieved by repeating the microphone scans.

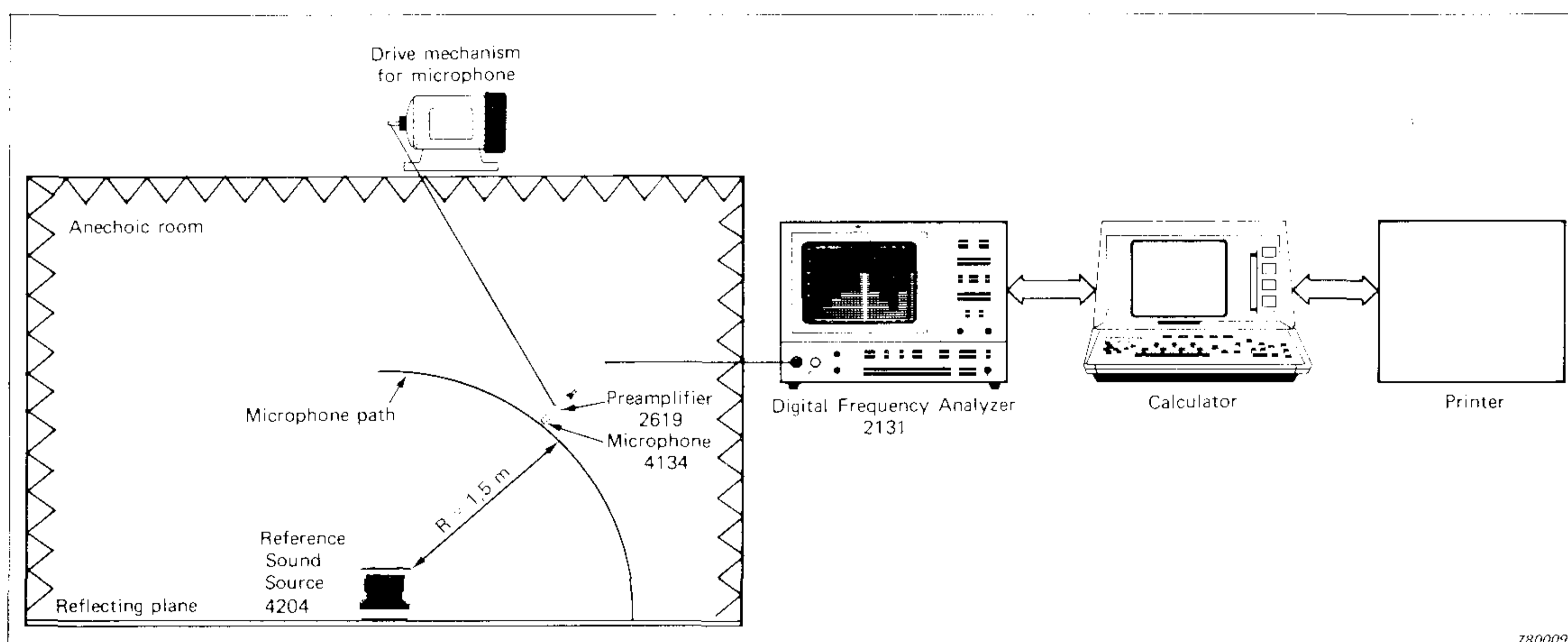

Fig.8. Measurement set-up for determination of the sound power level of a reference sound source in an anechoic room. Note the simple manner in which the cosine function for area weighting is automatically taken into account by lifting the microphone at a constant vertical velocity

Possible errors must therefore be sought in the anechoic room itself. If the room is not sufficiently absorbant, reflections from the walls introduce errors, and if the sound source is highly directive, the reflections can be further accentuated. These, however, can be identified by using a different microphone distance. If the same results are obtained, the room can be assumed to be satisfactory.

In most anechoic rooms the sound source is placed on a heavy plywood floorboard. A possible error could arise if the plywood floor vibrated and thus radiated acoustic energy, especially at low frequencies. In this case the sound power determined would be greater than when determined if the source was placed on a heavy foundation.

For these measurements the plywood used in the anechoic room was $2,44 \times 2,44 \text{ m}^2$ and approx. 2 cm thick. The vibration of the floorboard was measured using accelerometers and found to be small compared to the power radiated from the sound source itself, indicating negligible error.

To further ensure that this source of error was avoided, measurements were also performed outdoors on a heavy asphalt foundation away from buildings and other obstacles. The microphone positions are indicated in Fig.9. The measurements were carried out on a day with very little wind and low background noise. By comparison of the outdoor measurement results with the results obtained in the anechoic room, it was not only possible to establish that the plywood foundation did not give any contribution to the low-frequency energy, but also to verify that the anechoic room was sufficiently adequate.

Fig.10 shows a few measurement results obtained in the anechoic room and in open air. It can be seen that the differences between the two sets of results are very small and are not systematic. At low frequencies the deviations are practically negligible. At higher frequencies a slightly higher level is obtained in open air than in the anechoic chamber which is probably due to the sound reflection being greater from asphalt than the plywood used in the anechoic chamber.

The free-field measurement results can therefore be regarded as very accurate, and can be used as reference values. ISO standards also indicate that the results obtained in an anechoic room according to 3745 are approximately 3 times more reliable than those obtained in a reverberation chamber according to 3741.

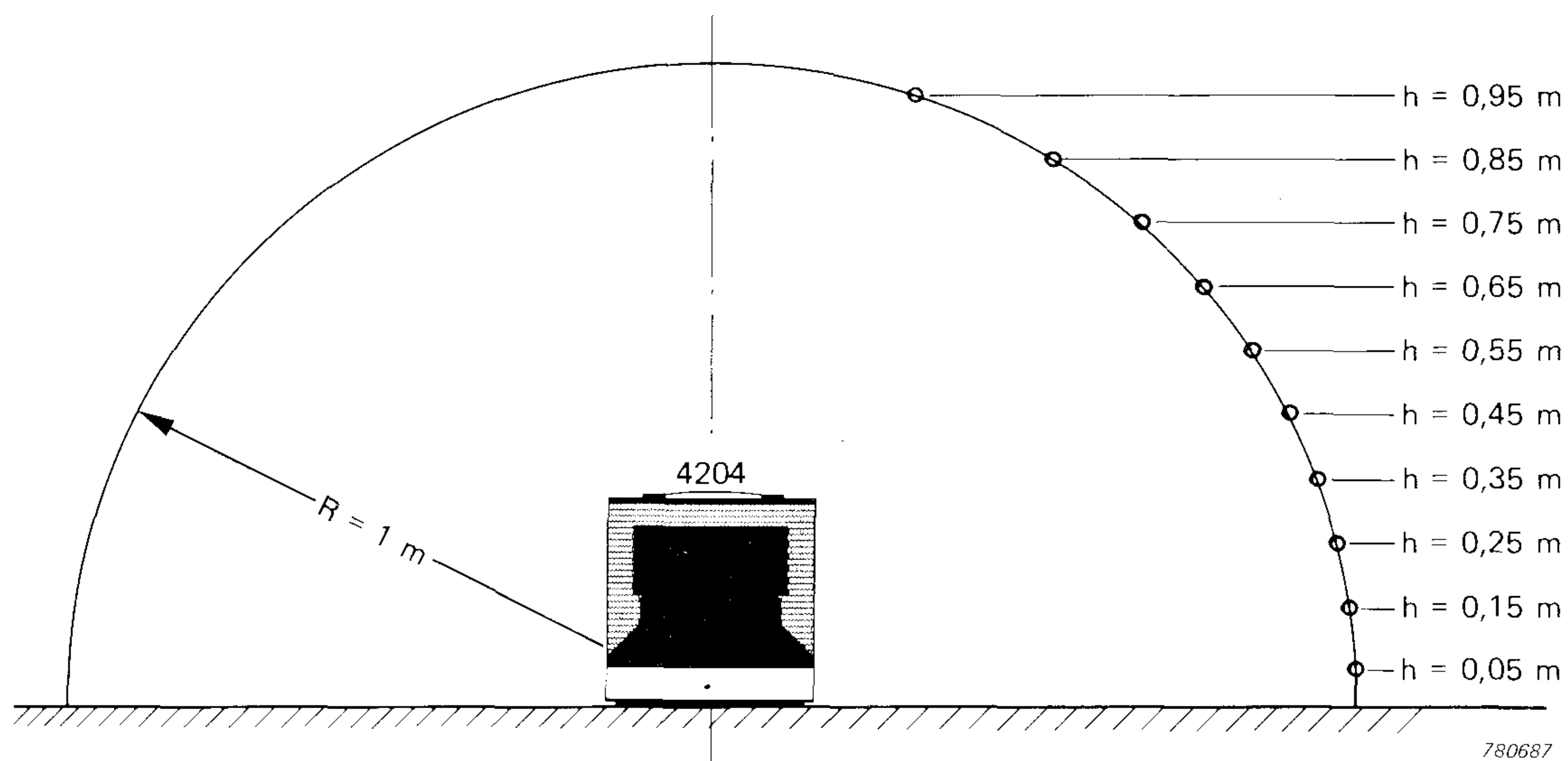

Fig.9. Microphone positions used for measurements performed in open air over asphalt surface. 10 different microphone positions are used, and the symmetry of the sound source is also checked

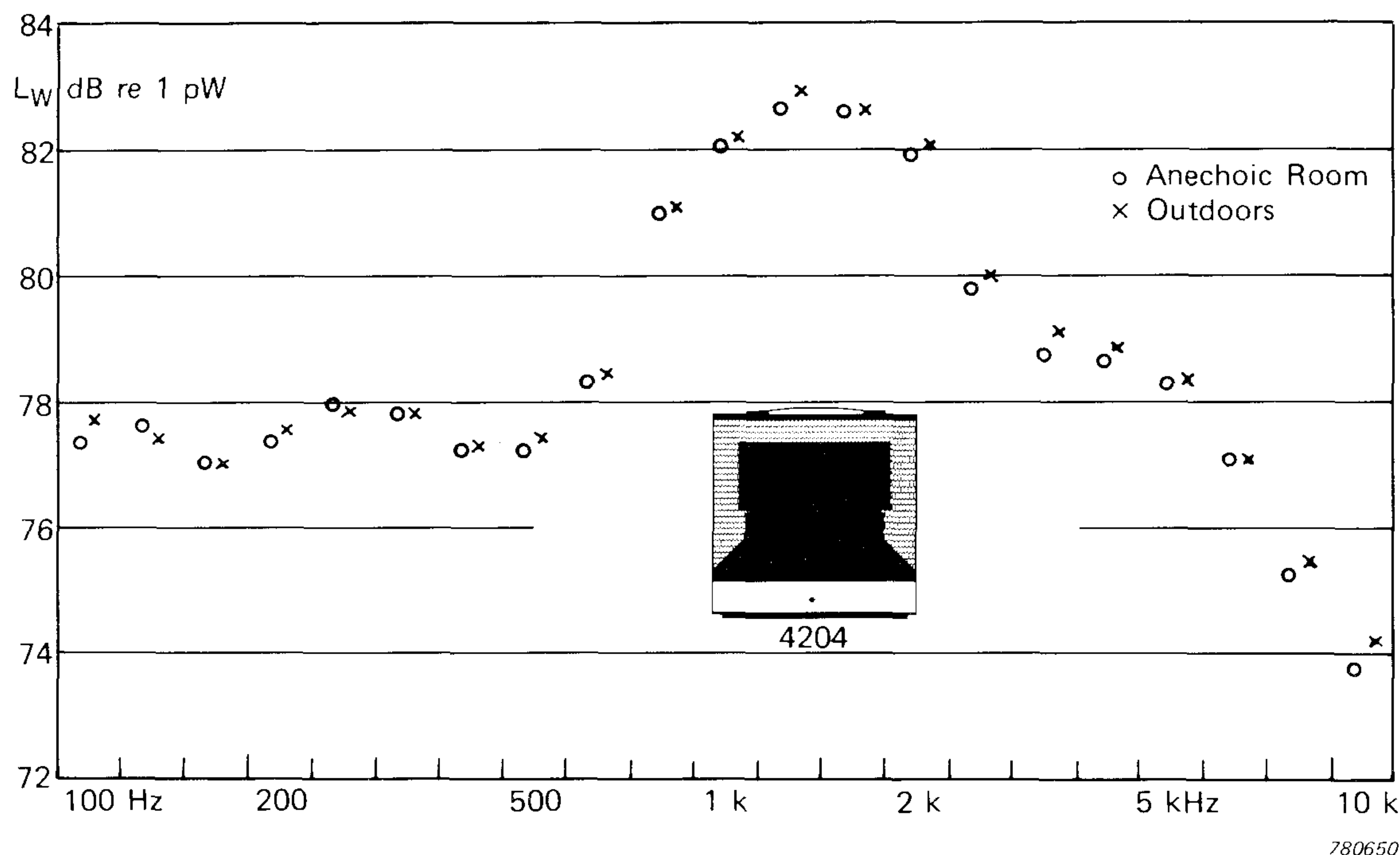

Fig.10. Comparison of sound power levels obtained in an anechoic chamber and in open air over a reflecting asphalt surface for the same sound source

Sound Power Measurements in Reverberation Rooms

The sound power level of a sound source in a reverberation room can be determined from the following equation which is given in reference [1].

$$L_W = L_p + 10 \log \frac{V}{V_o} - 10 \log \frac{T}{T_o} - 14 + 10 \log \left(1 + \frac{c \times S}{f \times 8 \times V} \right)$$

In this formula, the different symbols are as follows:

Sound Power Level	L_w	dB re. 10^{-12} Watt
Mean Sound Pressure Level	L_p	dB re. 2×10^{-5} Pa (N/m^2)
Volume of the Reverberation Room	V	m^3
Reference Volume	V_o	$1 m^3$
Reverberation Time	T	s
Reference Reverberation Time	T_o	1 s
Sound Velocity at Room Temp.	c	m/s
Surface area of Reverberation Room	S	m^2
Frequency	f	Hz

It can be seen from the expression, that the sound pressure level L_p and the reverberation time level ($10 \log T/T_o$) play an equally important role in determining the sound power level. Both should therefore be measured (with the greatest accuracy) in contrast to measurements in the free-field where only the mean sound pressure level has to be determined.

Furthermore, the sound pressure in the free-field for a non-directional source is far more uniform than the sound pressure in the reverberation room where it varies significantly from position to position due to all the interferences in the room. It is chiefly for these reasons that the uncertainty in the determination of the sound power in the reverberation room is much higher than for the determination in the free-field.

For practical measurements two different rooms at the Danish Technical University (DTH) were used with the following specifications:

	Unit	Room 1	Room 2
Length	m	7,85	6,6
Width	m	6,25	3,6
Height	m	4,95	3,45
Volume	m ³	243	69,4
Surface area (without diffusers)	m ²	238	107
Temperature	°C	18	22
Static Pressure	mm Hg	754	746
Number of diffusers		20	None
Surface area of diffusers	m ²	0,9 x 1,2	
Reverberation Time at 500 Hz	s	9,2	0,75

780188

Table 2

Fig.11 shows a sketch of the measurement equipment. The sound pressure was measured for four different sound source positions on the floor and for each position and each third octave band the levels were integrated linearly for two microphone rotation periods of 64 s by the Noise Level Analyzer Type 4426.

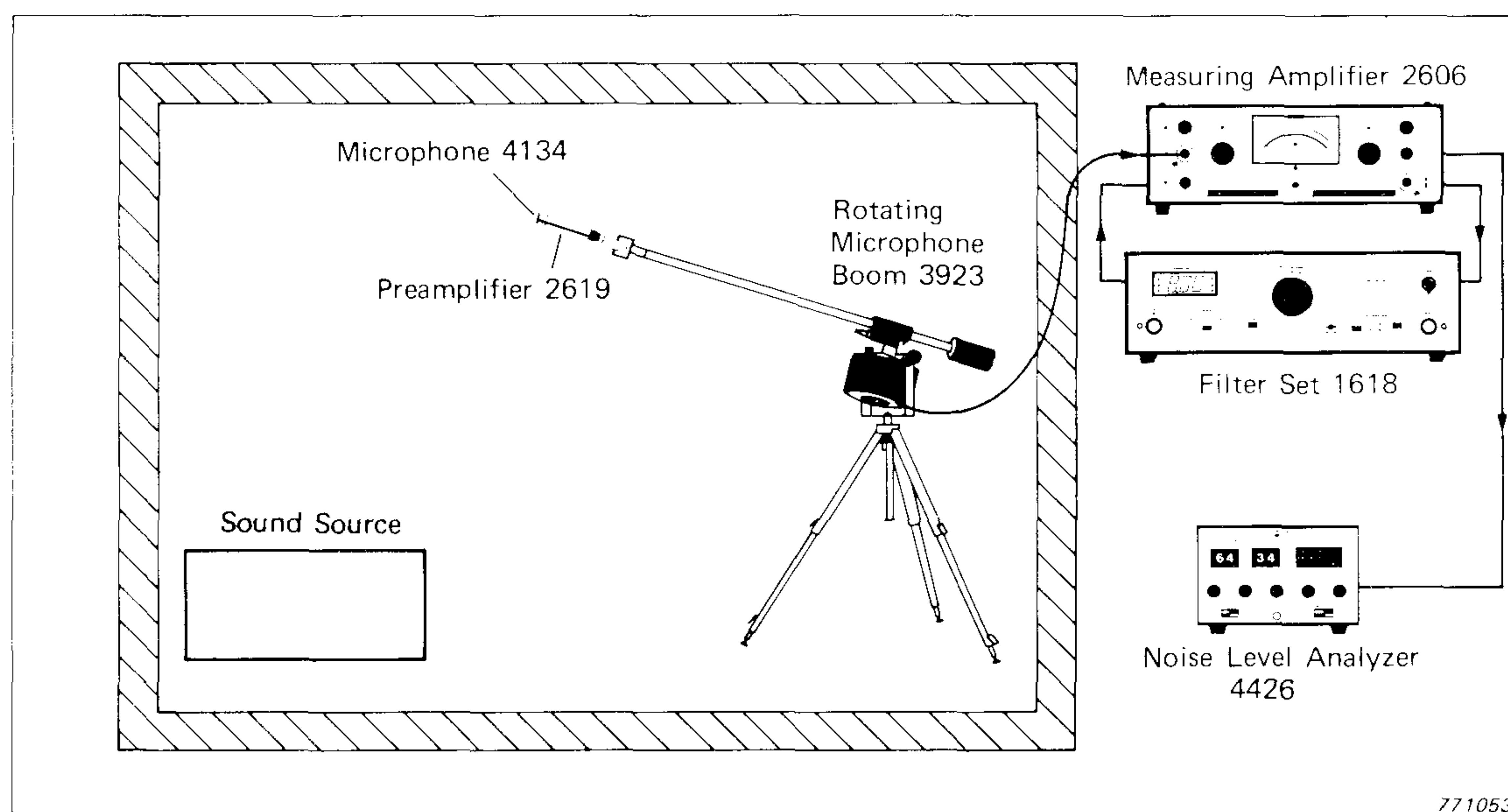

771053

Fig.11. Measurement set-up for determination of time and space average of sound pressure level in a reverberation room using a scanning microphone and a linearly integrating meter

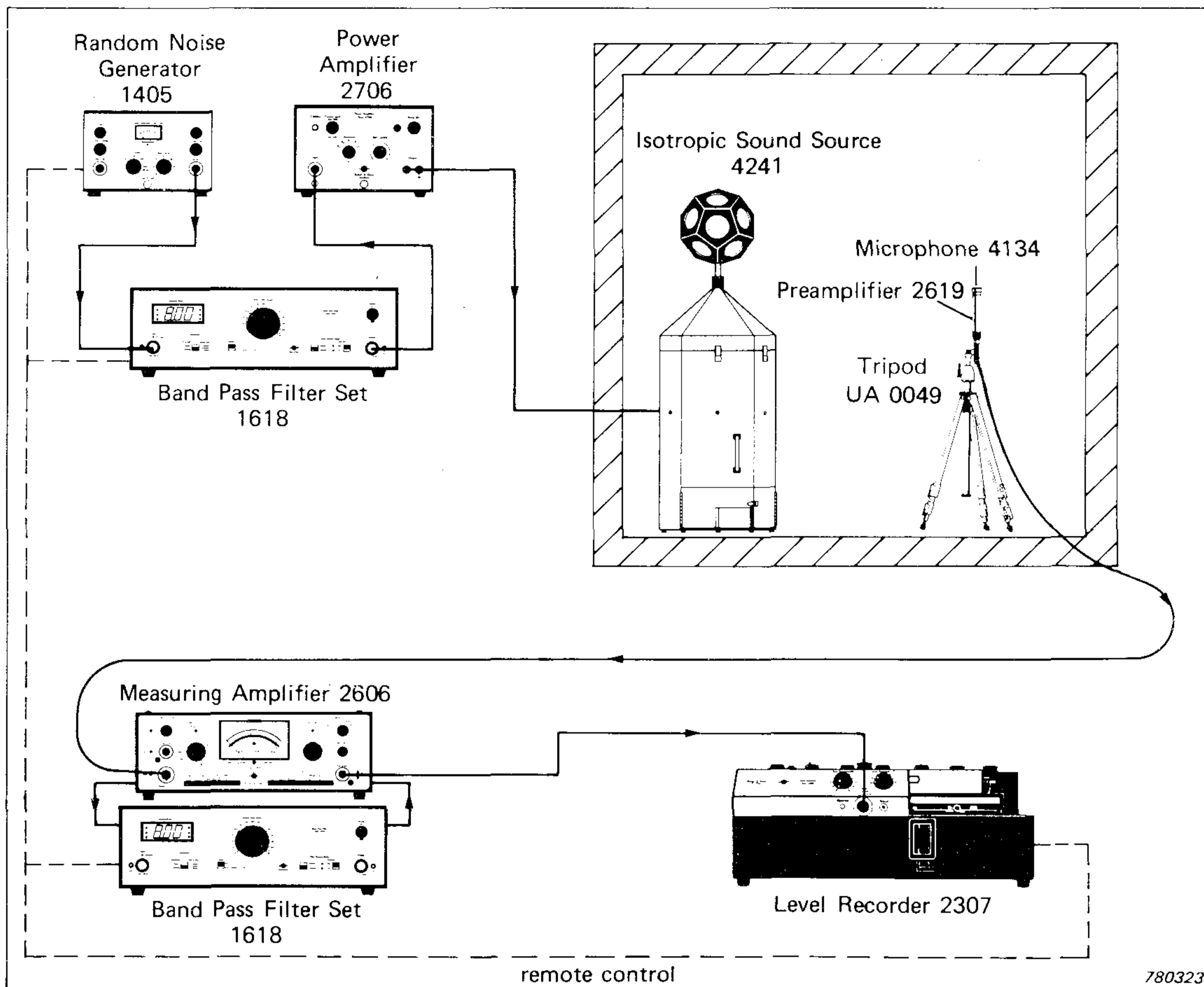

Fig.12. Semi-automatic measurement set-up for reverberation time

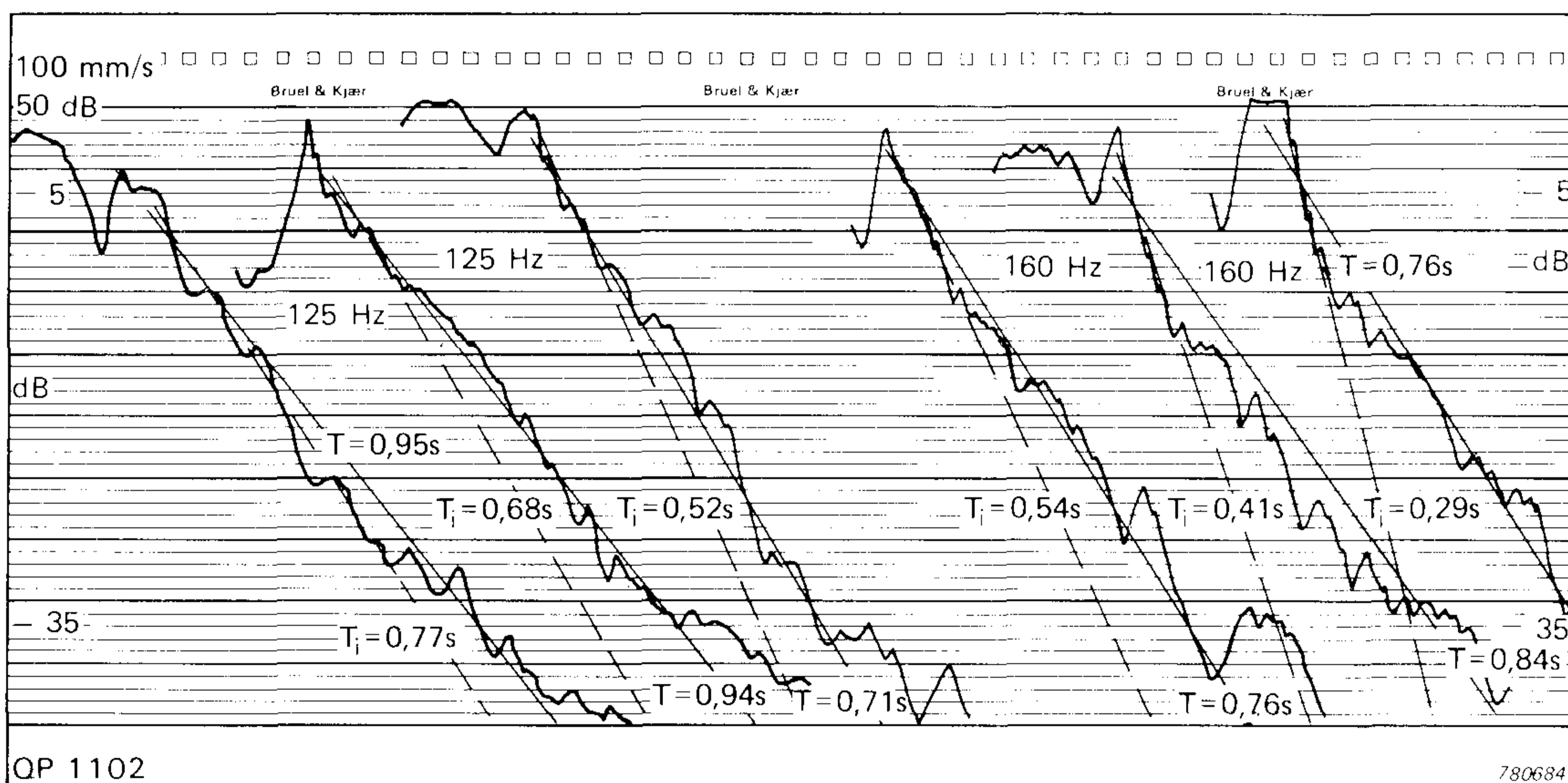
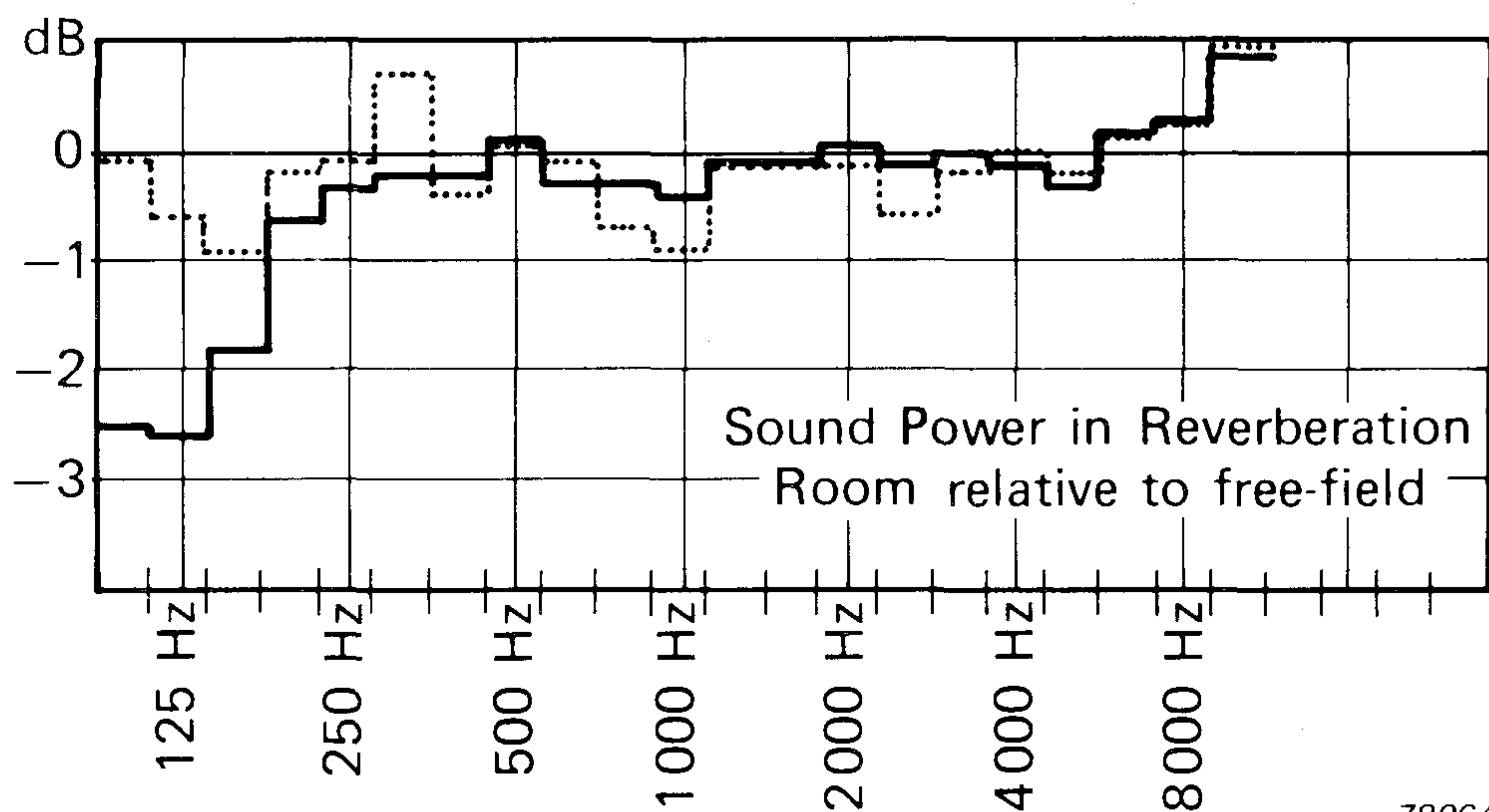

Fig.13. Examples of low frequency decay curves. T is the reverberation time obtained from the slope between -5 and -35 dB levels. T_i is reverberation time from early decay rate

The absorption of the test room was determined using the classical method by recording the decay curves on a level recorder, Fig.12, and determining the reverberation time. Several curves for each third octave band were recorded to obtain an average value.

Fig.13 shows some typical decay curves for the 70 m^3 room for low frequencies, and it can be seen that the fluctuations make an exact determination of the decay rate rather difficult. According to ISO Standards the decay rate is determined from the slope of a straight line in the region from -5 to -35 dB below the stationary level.

Using these values the output power of the Reference Sound Source Type 4204 was determined for each third octave band and compared with the output power determined in the free-field. The results are shown in Fig.14, where the levels for the diffuse field at low and medium low frequencies are lower as expected. At higher frequencies the results between the anechoic chamber and the reverberation room method do not show any systematic differences. Even though all possible care has been taken, and many measurements have been carried out and averaged, the uncertainty is still high.



780647

Fig.14. *Difference between sound power measured in a 240 m^3 reverberation room and in the free-field*

Solid curve: Difference using reverberation time determined in the room over 30 dB.

Dotted curve: Difference using reverberation time determined over the first 10 dB of the recorded reverberation curves

From Fig.13, it can be seen that the reverberation curves seem to be concave with a higher decay rate just after the sound source has been switched off. If this early decay of the reverberation curve is used for determination of the absorption in the test room, the agreement between free-field and diffuse-field results is much better as shown in Fig.14 by the dotted curve.

Measurements with an automatic system

To increase the measurement accuracy, a more sophisticated automatic system shown in Fig.15 was used where a large number of sound pressure measurements can be made simultaneously in all third-octave bands by means of a Real-Time Analyzer Type 2131 and a desk-top calculator. With this set-up, averaging can be performed over a very long time.

The reverberation time was determined using a similar rotating microphone, real-time analyzer and calculator (See Upton [9]). The Sound Power Source Type 4205 was used as a loudspeaker, and was also rotated slowly on a swing arm using a turntable close to the floor. The two rotations were out of synchronism and in different planes. Each decay curve was broken up in 65 time intervals of 110 ms each. The levels for each time interval were averaged for 1600 decay curves whereby the mean decay curve obtained was thus averaged in time and space for both source and microphone positions. Measurements in all third octave bands were carried out simultaneously by means of the Digital Frequency Analyzer and the total time required for all the measurements was approx. 30 hours.

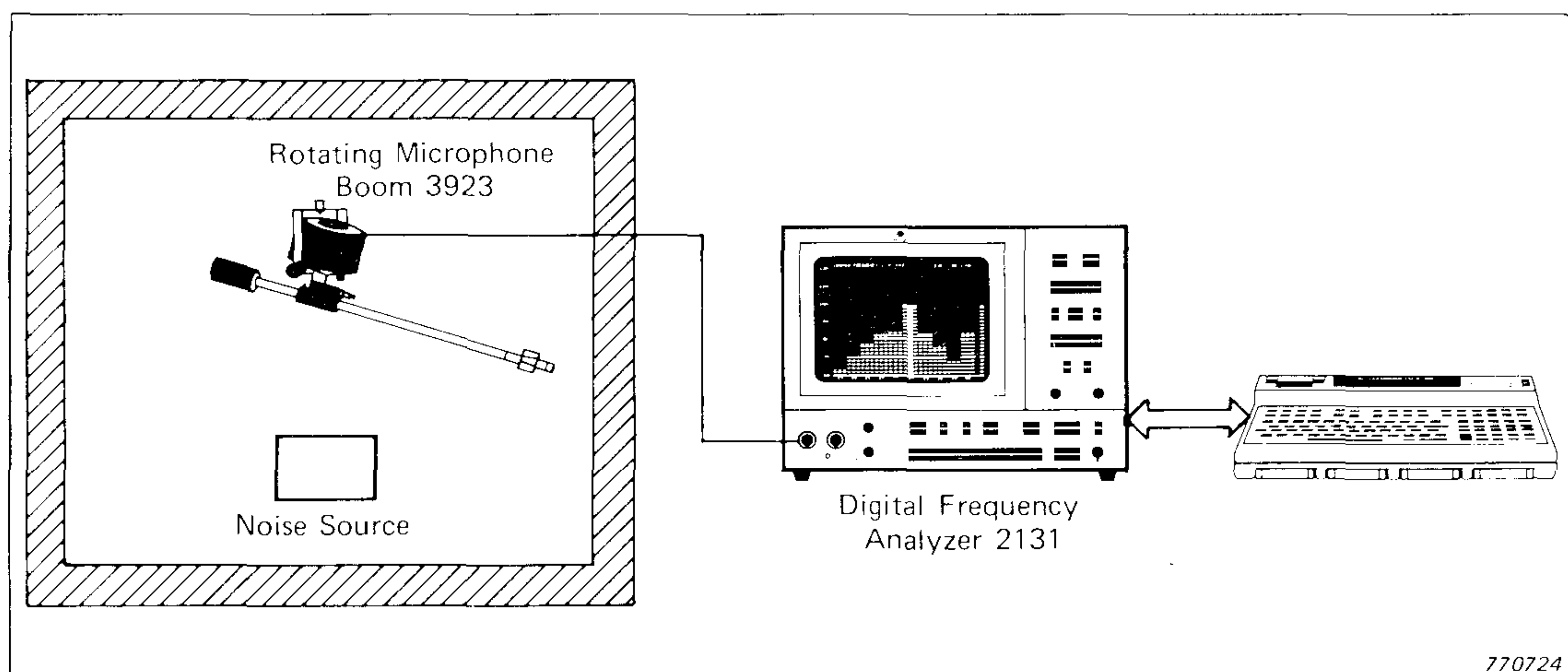

Fig.15. Automatic system for sound power measurements in a reverberation room

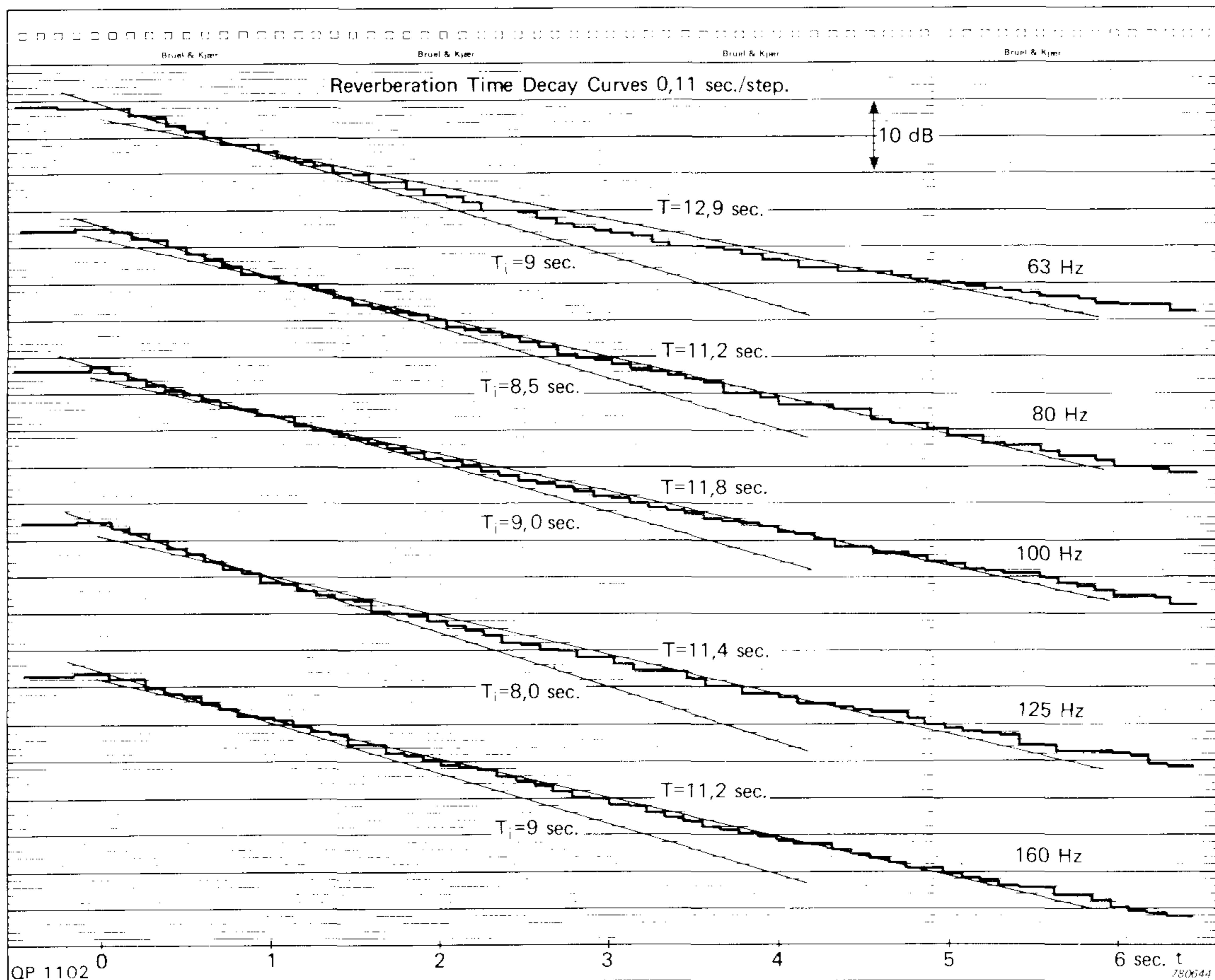

Fig.16. Averaged value of 1600 decay curves for the lower frequencies measured in a reverberation room (63 — 160 Hz)

Fig.16 shows these averaged decay curves for lower frequencies, and the reverberation time is determined over 30 dB (from -5 to -35 dB) as specified by the ISO standards.

As obtained with the level recorder earlier, it can be seen that the averaged decay curves are not linear but concave, such that the early part of the decay curve is steeper than the latter. On account of averaging a large number of measurement results, all the curves are free from random interference and consequently both the early decay and the decay rate between -5 and -35 dB can be determined with good accuracy. Similar curves shown in Fig.17 for the higher frequencies are not completely straight either. They are, however, much less curved, whereby the differences in the slope between the initial part of the decay curve and that measured according to the ISO standard (-5 to -35 dB) are not very significant.*

* These reverberation measurements are discussed in another article by Mr. Holger Larsen in Technical Review No.4—1978.

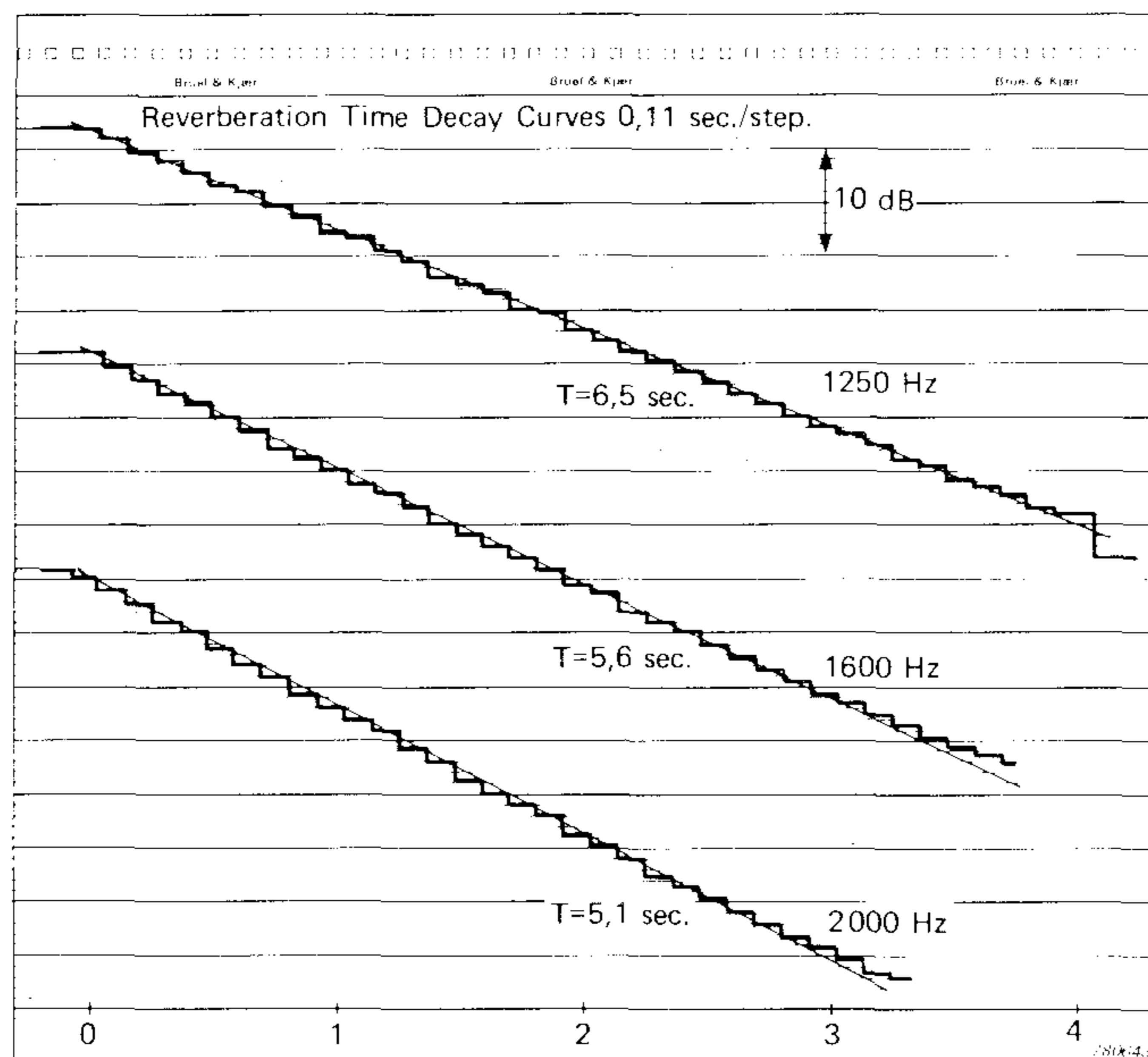

Fig.17. Averaged decay curves for higher frequencies (1,25 — 2 kHz)

On basis of the mean sound pressure level measured using the equipment shown in Fig.15 and the slope of the reverberation curves between -5 to -35 dB, the sound power is determined for each third octave band for the same source under identical conditions as those for the measurements in the anechoic chamber.

The results are shown in Fig.18, where it can be seen that for higher frequencies (over 400 Hz) there is very little difference between the measurements in the anechoic chamber and that in the reverberation room. However, there is a large deviation for the lower frequencies showing that the power determined in the reverberation room is less than that determined in the anechoic chamber, completely in agreement with the results from the literature cited earlier and shown in Figs.3 and 4.

The dotted curve in Fig.18 shows the difference between free-field and diffuse-field measurements when the reverberation time is determined from the initial part of the reverberation curve. It is clearly seen that in this case the agreement between free-field and diffuse field results is appreciably better.

This problem will be further discussed, but as a main conclusion it can be stated that by refined measurements it is possible to verify a *systematic* difference between reverberation room measurements and free-

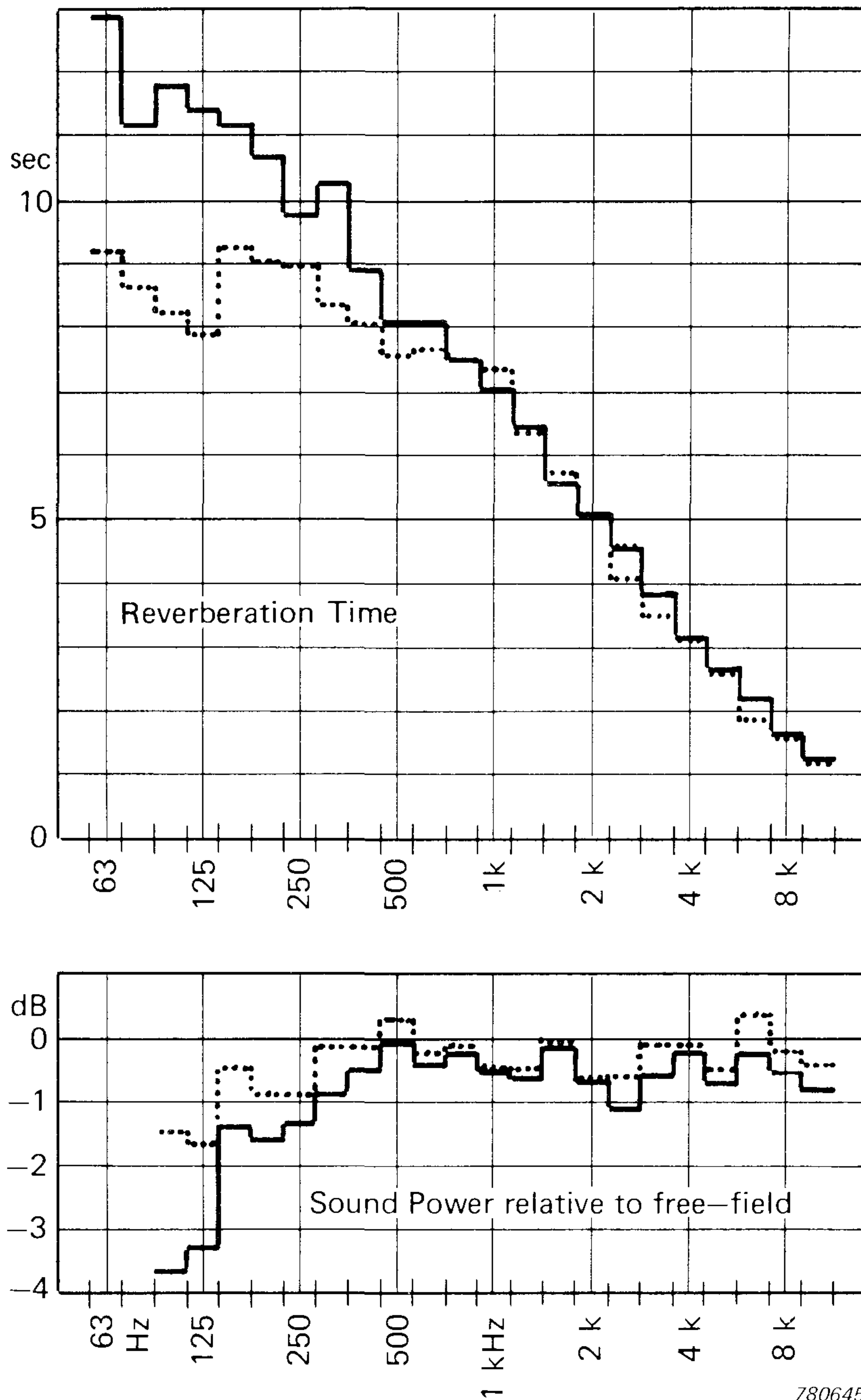

780645

Fig.18. Difference between sound power determination in a reverberation room and in the free field. Average values of a large number of measurements. Dotted curve obtained using early decay rate

field measurements. There are three possible explanations for these differences and will be examined in the following:

- 1) That the sound sources radiate less power at lower frequencies in a reverberation room than when they radiate in the free-field (Influence of Impedance)
- 2) That the sound power is not measured correctly by measuring the sound pressure in the reverberant field (Spacing between eigen-tones)
- 3) That the reverberation time is either measured or determined incorrectly.

1) The Influence of Impedance

The investigation of the influence of impedance on the radiated power of a sound source was carried out by determining the change in the sound pressure level in the middle of the room when the sound source was placed at different distances from the walls and corners of the reverberation room. If the impedance in the room should have a significant influence on the radiated power, it should clearly show up in these measurements, as the room impedance is different close to the wall than at some distance from it. It also varies radically from one point to another, depending on whether the sound source is placed at a velocity maximum or a pressure maximum for the different eigenmodes.

A series of measurements were carried out with a sound source placed in the middle of the 240 m³ room where the sound pressure level was averaged using a scanning microphone over the middle part of the room. The sound pressure level was therefore directly proportional to the power radiated from the sound source.

The source was now moved stepwise from the middle of the room towards the wall and the sound pressure level again determined for the same microphone scans. The difference in the sound pressure levels as a function of distance from the walls is plotted in Figs.19 and 20 for the sound sources 4204 and 4205 respectively. From the figures it can be seen that the radiated power at lower frequencies is highly dependent on the distance from the wall, indicating that at some places and for certain frequencies the sound sources radiate into a velocity maximum and in others into a pressure maximum.

The sound power radiated is also higher when the sound source is

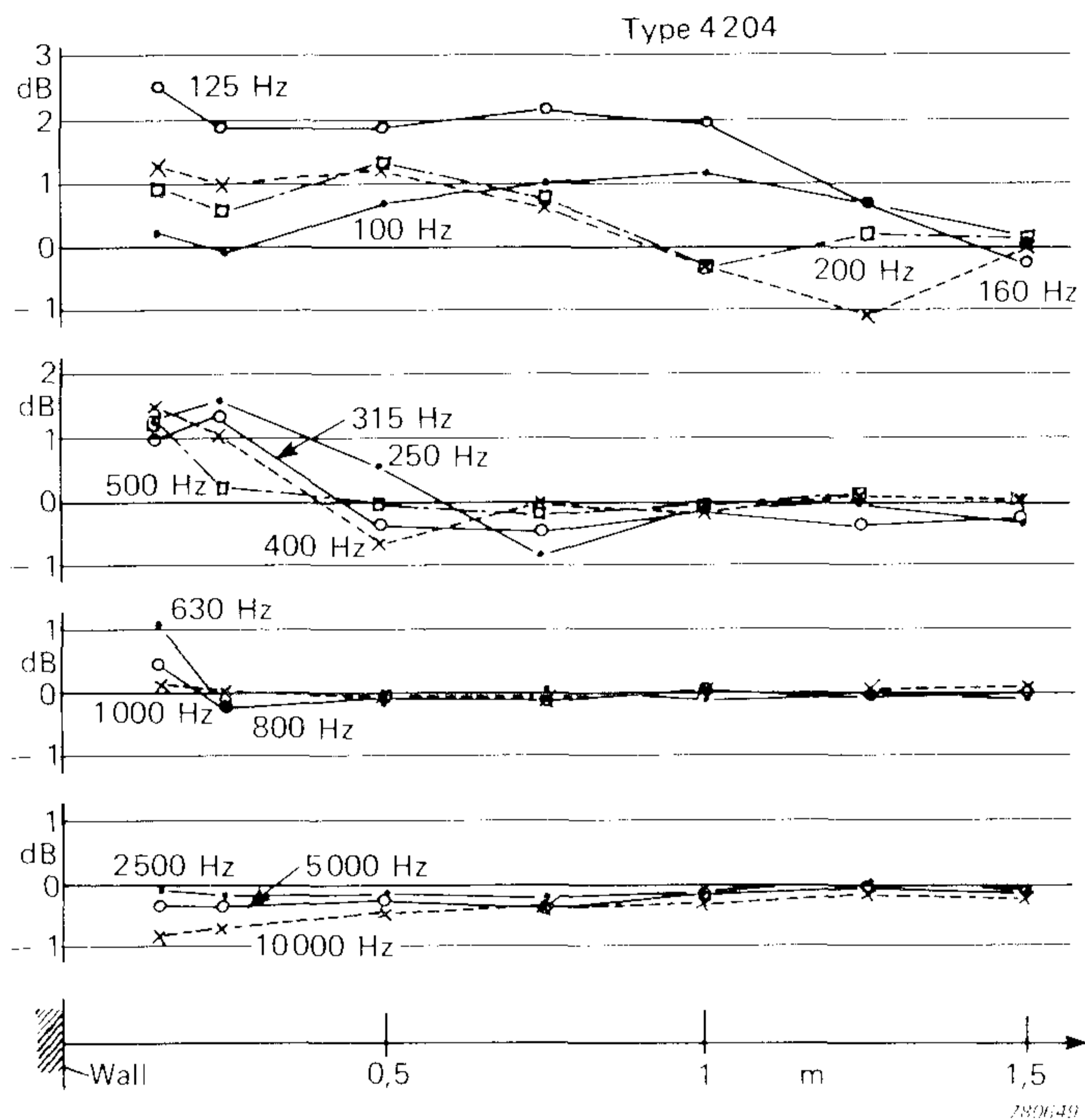

Fig.19. Difference between the sound power output from a Reference Sound Source Type 4204 when placed at different distances from a wall and when placed in the middle of the room. 240 m^3 Reverberation room at D.T.H.

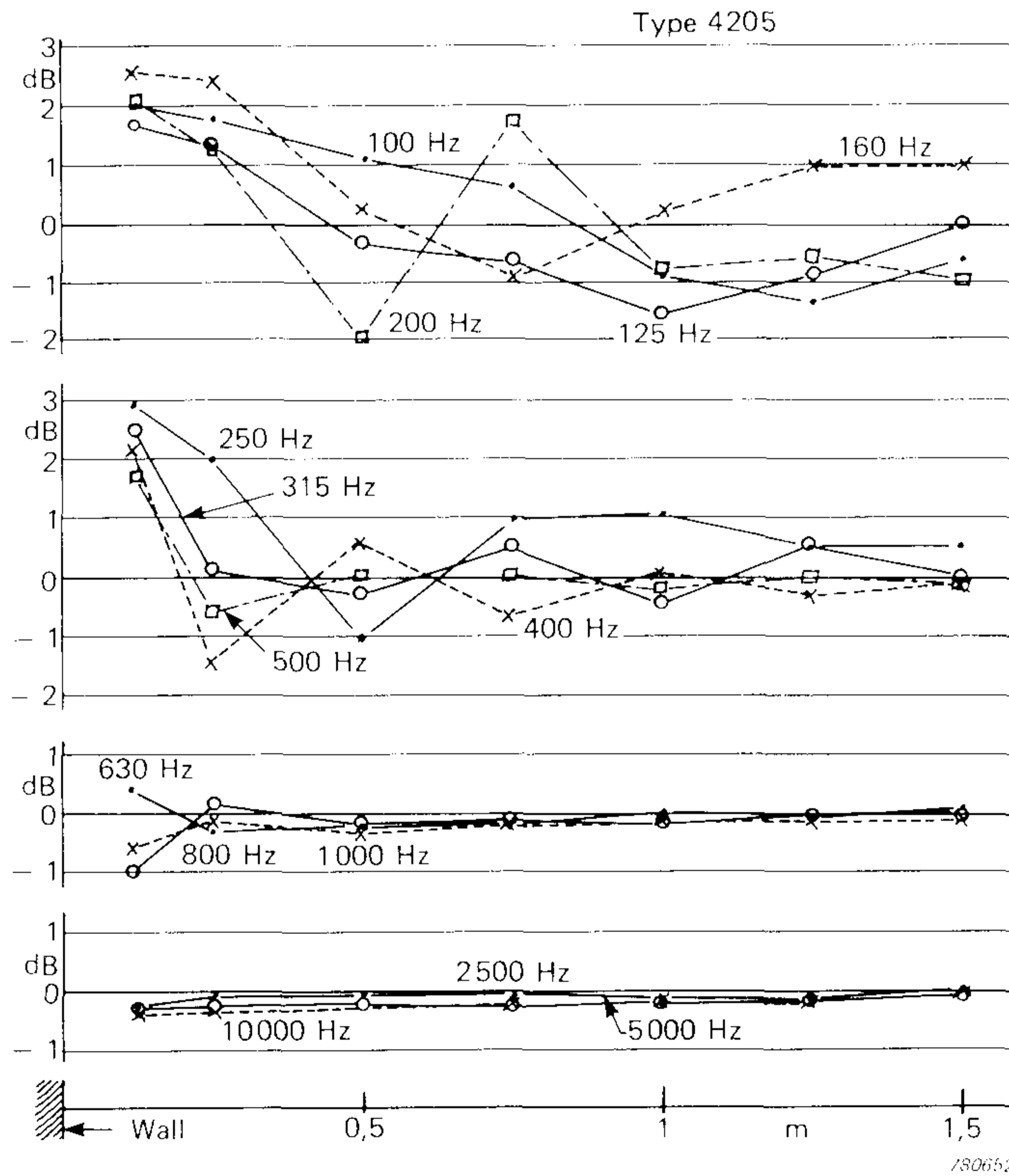

Fig.20. Same as Fig.19, but the sound source used was Type 4205

placed near the wall than when away from it. This is to be expected as the impedance close to the wall at lower frequencies is always higher than the impedance in the middle of the room. However, already at a $1/2$ wavelength distance from the walls these systematic errors seem to be equalized, and the sound pressure level varies *around* the mean value.

When the results for the larger Reference Sound Source Type 4204 are compared with those for the smaller Sound Power Source Type 4205, it can be seen that the variation in the sound pressure level is higher for the small source than for the bigger one. This is again obvious, as the bigger source is larger in relation to the wavelength and consequently its radiating surface equalizes some of the peaks and notches of the impedance irregularities. For higher frequencies over 600 Hz both sources are so large compared to the wavelength that practically all of the fluctuations are equalized.

From these measurements it can be concluded that the position of the sound source in the room is critical for the lower frequencies, and therefore for all sound power measurements it is necessary to carry out a series of measurements with different sound source positions and to average the results. A position close to the wall will in all cases give a systematic error; on the other hand, positioning the source at least $1/2$ wavelength distance away from the wall does not give any indication of a systematic error. Thus the systematic difference in sound power levels between free-field and diffuse-field measurements (which we are looking for) cannot be attributed to the influence of impedance in reverberation rooms.

Additional measurements were carried out with the Sound Power Source Type 4205 placed in the middle region of the room. The sound pressure level was measured with a moving microphone in the middle of the room while a second microphone was placed 3 cm from one wall, 3 cm from two walls, i.e. close to an edge, and 3 cm from three walls, i.e. in a corner. The difference in the sound pressure level between the fixed microphone and the moving microphone is shown in Fig.21 for the three positions.

According to simple statistical theory, the increase in sound pressure level when the microphone is placed near one wall, two walls and three walls should be 3, 6 and 9 dB respectively.

From Fig.21, it can be seen that the measurements agree very well with the statistical assumption, except when the distance of 3 cm from the wall is comparable with the wavelength, i.e. at frequencies over 1500 Hz the fixed microphone is sometimes at a velocity maximum, giving a large variation in the sound pressure level at higher frequencies.

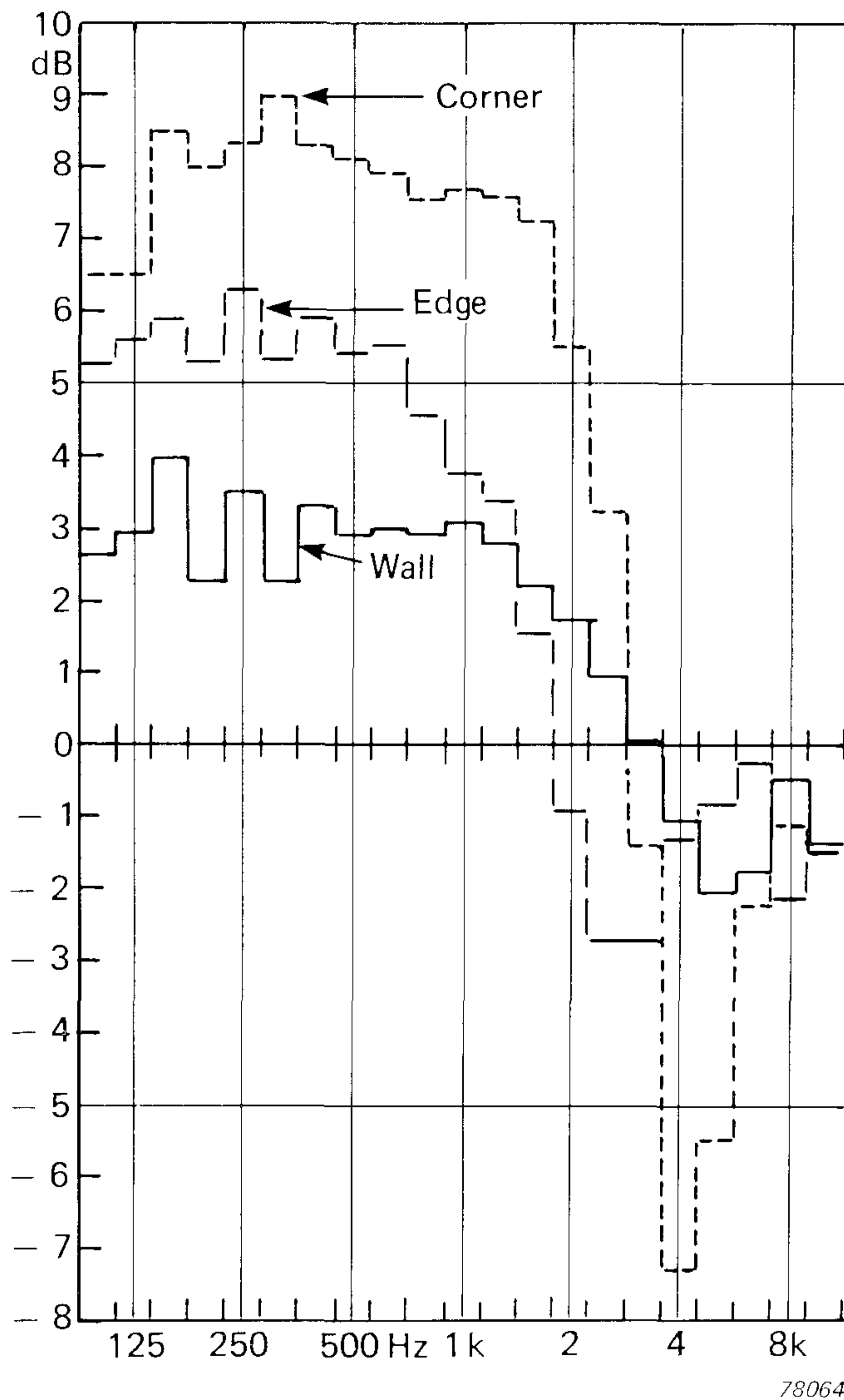

Fig.21. Sound pressure level near one wall, near two walls and near three walls (edge and corner) relative to the average sound pressure level measured by a moving microphone in the middle of the room, Sound Source (4205) placed far from walls

2) Spacing between Eigentones

For sound power measurements in a reverberation room, the sound pressure level should be measured in the diffuse field. This level is a

summation of the sound pressure contributions from a number of room resonances (sometimes referred to as normal modes or eigenmodes) excited by the sound source. The resonant frequency (eigentone) of a normal mode is a function of the room dimensions, while the damping is determined mainly by the absorption values of the boundary surfaces. The frequency of each normal mode can be calculated from the formula given in [11]

$$f_i = \frac{c}{2} \sqrt{\left(\frac{n_x}{l_x}\right)^2 + \left(\frac{n_y}{l_y}\right)^2 + \left(\frac{n_z}{l_z}\right)^2} \quad \text{Hz} \quad (1)$$

where n_x , n_y and n_z are integers

l_x , l_y and l_z are the room dimensions (m)

and c is the velocity of sound (m/s).

There are principally three different types of normal modes of vibration in a rectangular room and are illustrated in Fig.22 where all the three are shown to originate from the same wall.

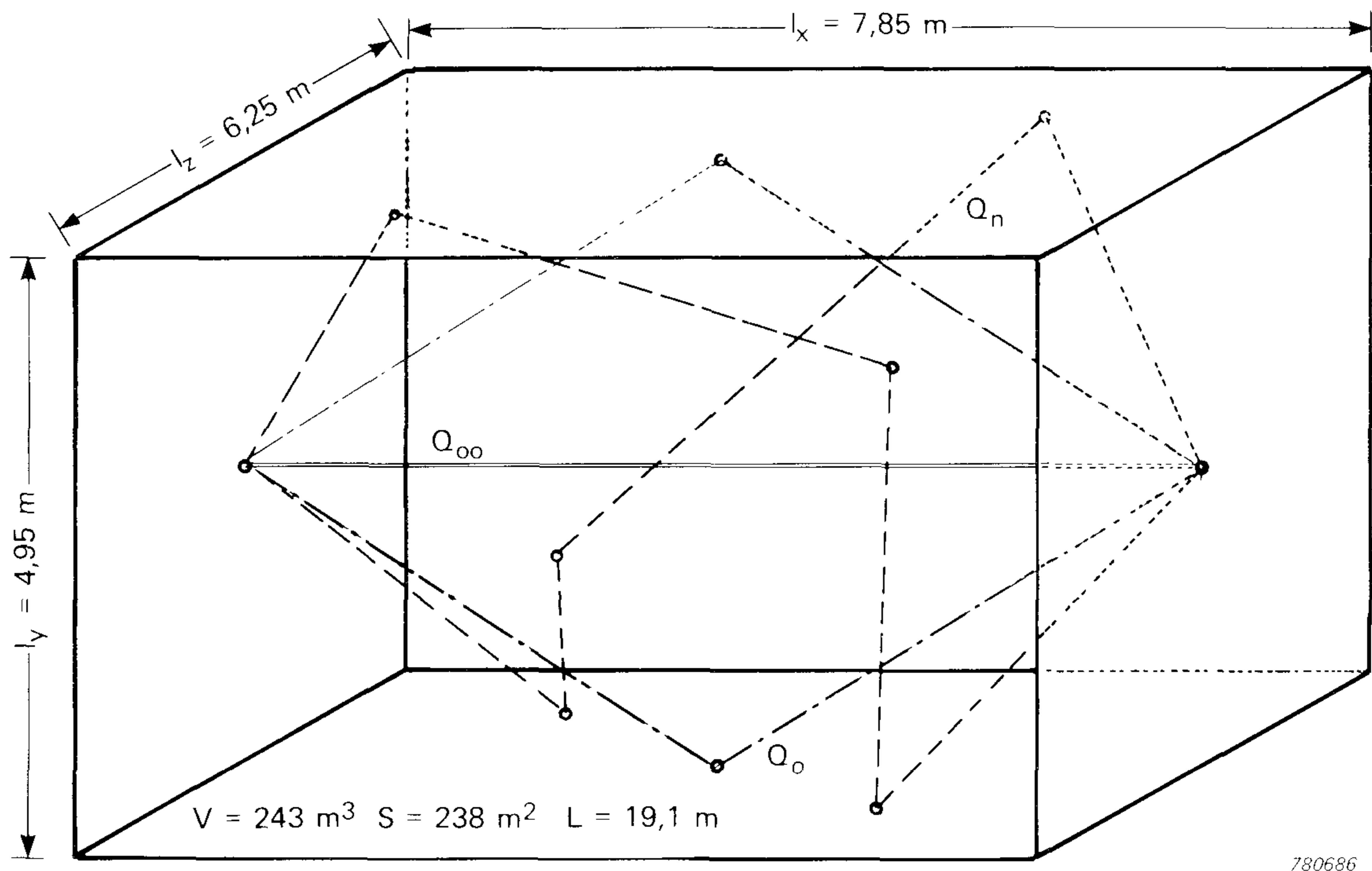

780686

Fig.22. Sketch of eigenmodes in a rectangular room showing the path of axial, tangential and oblique modes, all originating from a single wall

- a) In the *axial modes* (Q_{00}) the component waves travel along one axis (one dimensional) parallel to two wall pairs and are obtained by setting zeros for two of the n s in equation (1) i.e. $(n_x, 0, 0)$ $(0, n_y, 0)$ or $(0, 0, n_z)$. As the axial modes have the longest distance to travel between each reflection they have the lowest damping and thus the longest reverberation time.
- b) In the *tangential modes* (Q_0) the component waves are tangential to one pair of walls, but are oblique to the other two pairs (two dimensional) and are obtained by setting zero for one of the n s in equation (1) i.e. $(n_x, n_y, 0)$, $(n_x, 0, n_z)$ or $(0, n_y, n_z)$. As the waves here reflect between two wall pairs, the distance between each reflection is slightly shorter whereby the damping is higher and the reverberation time shorter than for the axial.
- c) In the *oblique modes* (Q_n) the component waves are oblique to all three pairs of walls (three dimensional) and are obtained when none of the n s are set to zero in equation (1). This is the main group of modes and as the waves are reflected between all three wall pairs they have the highest damping and thus the shortest reverberation time.

While it is important to know the centre frequency of each normal mode given by equation (1), a still more useful quantity to evaluate is the number of normal modes that have frequencies in a bandwidth Δf centred at f . Approximate expressions for this quantity ΔN for the three modes are

$$\text{Axial } (Q_{00}) \quad \Delta N = \frac{2L f}{c} \frac{\Delta f}{f} \quad (2)$$

$$\text{Tangential } (Q_0) \quad \Delta N = \left(\frac{\pi S f^2}{c^2} - \frac{2L f}{c} \right) \frac{\Delta f}{f} \quad (3)$$

$$\text{Oblique } (Q_n) \quad \Delta N = \left(\frac{4 \pi V f^3}{c^3} - \frac{\pi S f^2}{2c^2} + \frac{L f}{2c} \right) \frac{\Delta f}{f} \quad (4)$$

where $L = (l_x + l_y + l_z)$
 $V =$ volume of the room
 $S =$ surface area of the room

These equations are illustrated in Fig.23 for third octave band where ΔN is plotted against centre frequency f for the 240 m^3 room. From the figure it can be seen that the number of oblique modes increases much more rapidly with frequency than the number of axial and tangential modes. The exact number of normal modes calculated from equation (1) for third octave band are also plotted in the figure by crosses, circles and dots for (Q_{oo}) (Q_o) and (Q_n) respectively.

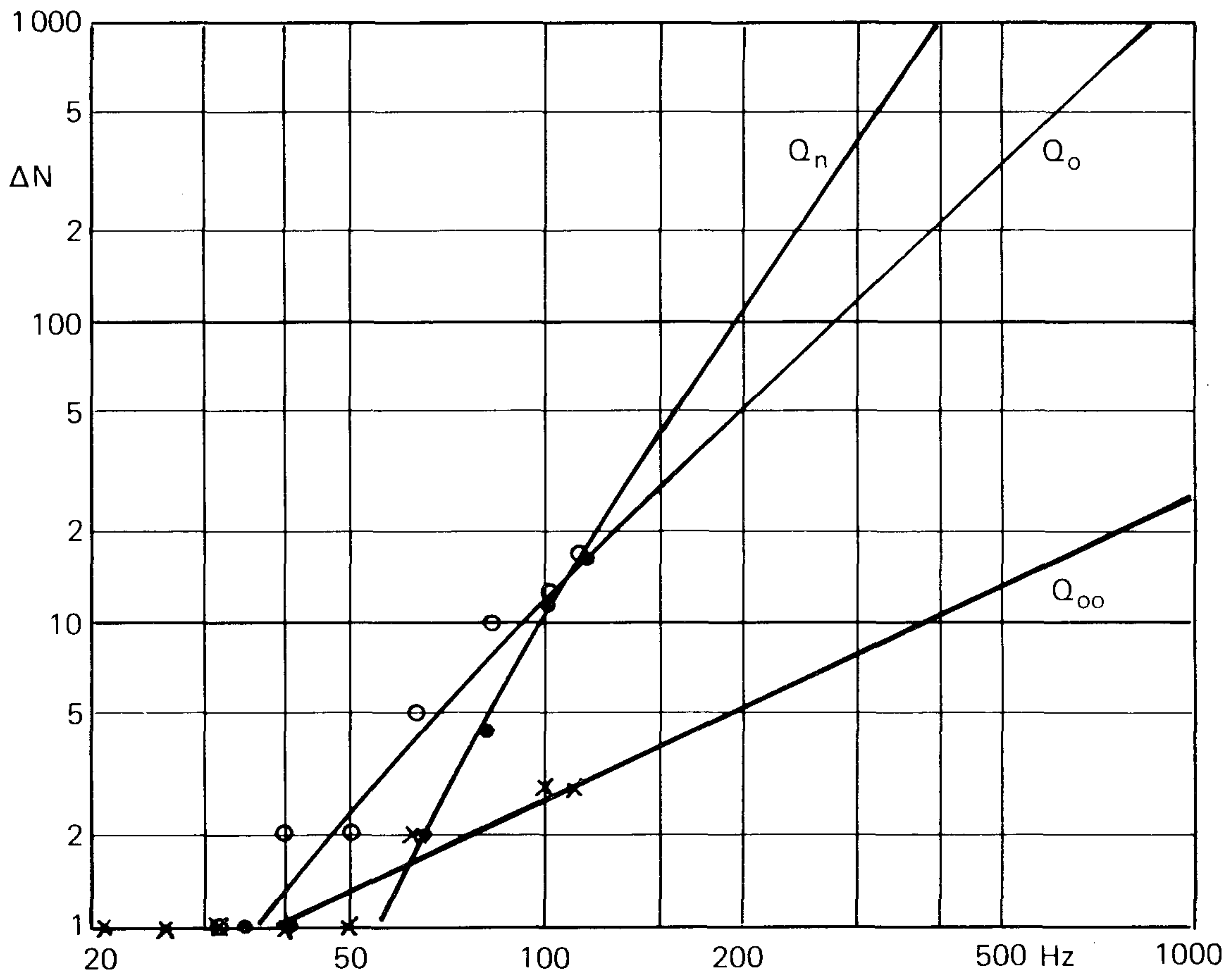

780685

Fig.23. Number of actual eigenmodes in the 240 m^3 room in each $1/3$ octave band represented by crosses, dots and circles. The curves are obtained from the abbreviated formulae. For higher frequencies the number of actual eigenmodes converge to the values given by the curves. The actual values are valid for the DTH 240 m^3 room and for a frequency band of one third octave

At low frequencies there are only a limited number of normal modes in a room of limited size and furthermore these modes have different

damping. As the damping is normally low in a hard room the bandwidth of the individual resonances would be small. If a high-impedance sound source emits white noise in a frequency range where there are few room resonances (normal modes), only a part of the frequency range would be represented in the diffuse field — namely the frequency regions lying near the resonant frequencies. At frequencies away from the resonances the excitation is greatly reduced and the contribution to the total sound pressure would be trifling. As a result the total sound pressure level measured, and hence the sound power evaluated, would be too low as compared to the case of the free-field where the contribution from the individual frequencies emitted by the source to the total sound pressure is independent of the room (where there are no resonances).

To illustrate the above in some detail, the normal modes of the 240 m³ room in the third octave band of centre frequency 63 Hz were closely examined theoretically. Assuming that the sound source radiates white noise, that the source and the microphone are scanned all over the room, and that the absorption coefficient is the same for all the walls and all angles of incidence, it is possible to calculate the relative level and effective bandwidth of each mode from the following formulae*:

$$\text{Relative Level } 20 \log \left(\frac{p_{io}}{p_{Bo}} \right) = \frac{\frac{l_i}{(\epsilon_{xi} \epsilon_{yi} \epsilon_{zi})^2}}{\sum_{i=1}^N \frac{l_i}{(\epsilon_{xi} \epsilon_{yi} \epsilon_{zi})^2}} \text{ dB} \quad (5)$$

$$\text{Effective Bandwidth } B_{\text{eff}} = \frac{c \alpha}{4 l_i} \text{ Hz} \quad (6)$$

where the mean free path of each mode l_i is given by

$$l_i = \frac{\sqrt{\left(\frac{n_x}{l_x}\right)^2 + \left(\frac{n_y}{l_y}\right)^2 + \left(\frac{n_z}{l_z}\right)^2}}{\left(\frac{n_x}{l_x^2} + \frac{n_y}{l_y^2} + \frac{n_z}{l_z^2}\right)} \text{ m} \quad (7)$$

* The formulae are derived in reference [10]

- α = absorption coefficient of the walls
- i = number of the normal mode
- p_{i0} = effective pressure of each mode
- p_{B0} = total pressure of third octave band.
- ϵ = 1 for $n = 0$
- ϵ = 2 for $n > 0$
- N = total number of normal modes in the third octave band

From the equations it can be seen that the relative level is a function of l_i while the effective bandwidth is a function of both l_i and α . In Table 3 the values evaluated for $\alpha = 0,024$ and $\alpha = 0,15$ are given. Fig.24 shows graphically the relative levels and effective bandwidth of the eight modes in the third octave band of centre frequency 63 Hz. The levels of the modes are shown relative to the 0 dB level which correspond to the total sound pressure level in the third octave band. When the absorption coefficient is increased from 0,024 to 0,15 the effective bandwidths of the modes are increased as can be seen in Fig.24. The whole frequency range is now practically "covered" by effective bandwidths and hence the spectrum of the sound source will be better represented by the total sound pressure level in the third octave band. A figure of 0,16 for the absorption coefficient at low frequencies has also been suggested in the ISO standards and seems to be a good practical value.

i	n_x	n_y	n_z	$\epsilon_x \epsilon_y \epsilon_z$	f_i [Hz]	l_i [m]	$20 \log \left(\frac{p_{i0}}{p_{B0}} \right)$ [dB]	B_{eff} [Hz]	
								$\alpha = 0,024$	$\alpha = 0,15$
1	1	2	0	4	58,6	5,11	- 11,3	0,40	2,50
2	2	1	1	8	61,6	3,67	- 18,7	0,56	3,47
3	0	2	1	4	64,3	4,11	- 12,2	0,50	3,10
4	3	0	0	2	65,0	7,85	- 3,4	0,26	1,62
5	1	2	1	8	67,9	3,69	- 18,7	0,55	3,45
6	0	0	2	2	68,7	4,95	- 5,4	0,41	2,52
7	2	2	0	4	69,5	4,89	- 11,5	0,42	2,61
8	3	1	0	4	70,4	5,58	- 10,7	0,37	2,28

780190

Table 3

It is obvious that there is a need for a higher absorption coefficient only at the low frequencies where the "modal density" is low. At higher frequencies there will normally be an overwhelming number of modes sufficiently close together if the room dimensions have appropriate ratios of

$I_x:I_y:I_z$. Also at higher frequencies, higher absorption may cause a risk of beaming of the direct sound from the source to the microphone and thus add to the reverberant sound pressure level. The absorption at low frequencies should be spread out as broadly as possible over the surfaces of the room to even out the peaks and valleys of sound pressure occurring at widely different points on the surfaces.

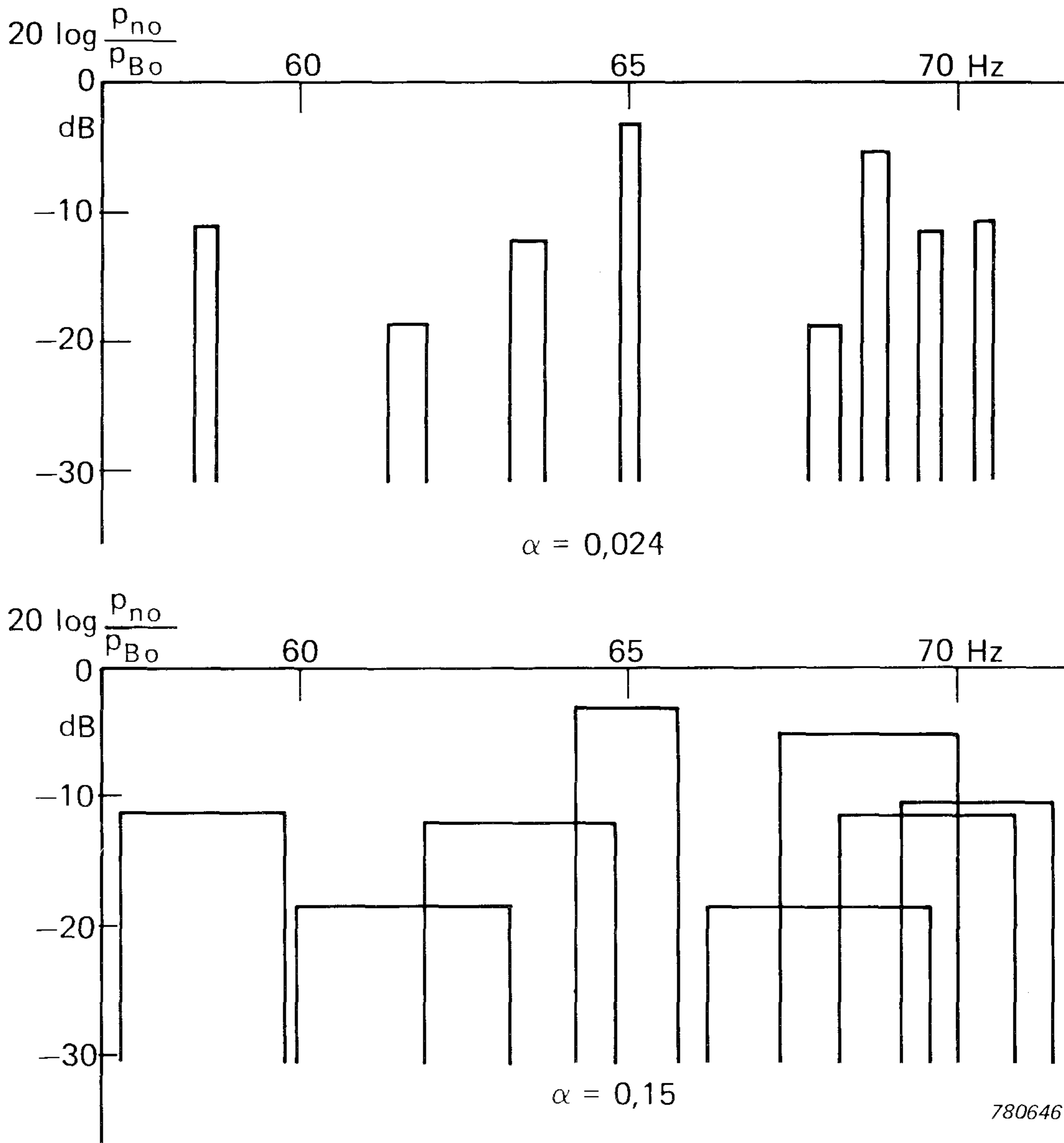

Fig.24. Levels and effective bandwidths of the eight eigenmodes in the 1/3 octave band of centre frequency 63 Hz
 Above for absorption coefficient = 0,024
 Below for absorption coefficient = 0,15

The third octave band of centre frequency 63 Hz was chosen simply for the sake of illustration as it contains only eight modes and are thus easy to handle, though sound power measurements should not be carried out in this frequency band. It can be concluded that the spread in the normal modes of a room could introduce some errors in the measurement of sound power in a reverberation room at very low frequencies. From Fig.18 it can be seen that this error could be between 1 to 2 dB in the third octave band of centre frequency 100 Hz though already at 200 Hz and above, this error is negligible when the room has a size in the order of 200 m³.

3) *Reverberation Time Measurements*

The final possible explanation for the difference between free-field and diffuse field sound power results involves the investigation of reverberation time measurements.

Fig.13 and 16 illustrated earlier, show that the reverberation curves for lower frequencies are concave with an appreciably steeper decay at the beginning of the curve than at low levels, whereas at high frequencies the reverberation curves are practically linear over a large dynamic range.

A factor of 1 to 2 between the early decay and the average decay between -5 to -35 dB is very common at the lower frequencies. However, it can be shown that it is the reverberation time obtained from the early decay which is decisive for sound power measurements, and thus an error of approximately 1,5 dB occurs exclusively for that reason.

A thorough analysis of some of the details concerning reverberation time measurements and the early decay will be published by Mr. Holger Larsen [10] and therefore only the conclusions will be made here.

The dotted line results shown in Fig.18 are obtained by using the early decay rate for the reverberation time, and it can be seen that the agreement is much better than when using the ISO recommended method for determining the reverberation time. Also the measurement results illustrated in Fig.14 obtained using conventional methods show a much better agreement by using the initial part of the decay curve recorded on the graphic level recorder.

Conclusion

It has been shown that the determination of the reverberation time from the early decay rate is essential to correctly determine the sound power in reverberation rooms at low frequencies.

It is therefore rather unfortunate (at least for the case of sound power measurements) that ISO in Recommendation 354 has suggested that the reverberation time should be measured from -5 to -35 dB, as this may lead to errors of several dBs in the low-frequency range. On the other hand, measurement of the early decay rate of the reverberation curve is not simple using conventional methods, though accurate results to some extent can be obtained using modern instrumentation.

It is also shown that the position of the source in the reverberation room plays an important role in the determination of its sound power. It is therefore recommended that the sound power is determined for several sound source positions, and an average value evaluated. As a practical guide three different positions should normally be sufficient. Likewise, the microphone should be placed at several positions or a scanning microphone should be used.

When precautions are taken to avoid all the possible errors that may arise, it is evident that the absolute determination of sound power in a reverberation room is a complicated and time-consuming procedure. Even with the utmost care the accuracy achievable by this method could never be as high as that obtained by the free-field method.

If a standard reference sound source is used to compare the sound power output of an unknown source in the reverberation room, several sources of errors mentioned above are minimised. Firstly, problems concerning the early decay rate are avoided as reverberation time measurements are not required. Secondly, if it is possible to place the reference source in the same position as the source under test, the influence of the source position in the room is to a great extent minimised.

By using the same microphone positions for the measurement of both the reference source and the unknown source, also the errors introduced on account of using a limited number of microphone positions are partly overcome.

The reference source can be calibrated with a high degree of accuracy in the free-field, and its stability can be controlled by measuring the sound pressure in the near field (for the 4205).

Building Acoustics

In the building industry the determination of the sound insulation for walls, windows and doors has for many years been performed using two rooms - separated by a wall under test. While one of the rooms is excited by a sound source the sound pressure is measured in both the rooms, and from the difference the sound insulation of the partition is determined. It is obvious that, the sound pressure in the receiving room is dependent on the total absorption of this room, which is normally determined by measuring the reverberation time.

There have always been difficulties in obtaining good accuracy and agreement in the insulation figures for the same wall measured in different laboratories and in actual buildings. The difference is particularly noticeable at low frequencies.

Since insulation measurements are in reality only a determination of the sound power radiated from the wall under test into the receiving room, it can be seen that all the problems dealt with in this article are also relevant for measurements in the building industry.

It can be concluded that most of the insulation measurements carried out according to ISO Standard 140 are probably incorrect at the low frequencies. Most of the partitions measured do not insulate as well in practice at the low frequencies as the measurements predict. The correct method and in many respects also easier, would be to use a standardized sound source for the determination of the absorption of the receiving room.

References

- | | |
|---|---|
| 1. ISO 3741 (1975)
Corresponds to ANSI
SI.21-1972 | Precision Methods for Broad-Band
Sources in Reverberation Rooms |
| ISO 3742 (1975)
Corresponds to ANSI
SI.21-1972 | Precision Methods for Discrete-Fre-
quency and Narrow-Band Sources in Re-
verberation Rooms |
| ISO 3743 (1976) | Engineering Methods for Special Reverb-
eration Test Rooms |

- DIS 3744.2 (1977) Draft only: Engineering Methods for free-field Conditions over a Reflecting Plane
- ISO 3745 (1977) Precision Methods for Anechoic and Semi-Anechoic Rooms
2. BERANEK, L.L. Noise and Vibration Control, Chapter 6. McGraw-Hill, New York, 1971
 3. WELLS, R.J. & WIENER, F.M. On the Determination of the Acoustic Power of a Source of Sound in Semi-Reverberant Spaces, p.21. Noise Control, January 1961
 4. BURGER, MERWE, ZYL & JOFFE Measurement of Sound Intensity Applied to the Determination of Radiated Sound Power, p.1167. JASA, Vol.53, 1973
 5. KRAMAR, O. Measurement of Sound Absorption of Rooms Using Reference Sound Source, p.26. Brüel & Kjær Technical Review No.4, 1976
 6. FRANCOIS, P. Characteristics and Calibration of Reference Sound Sources, p.14. Noise Control Engineering July-August 1977
We are grateful to Mr.P. Francois for permitting us to use Fig.5.
 7. JUHL PEDERSEN, O. Standards for the Measurement of Noise from Household Appliances 1976 Noise Control Conference, Warsaw, October, 1976
 8. LARSEN H. An Easy and Accurate Method of Sound Power Measurements, p.3. Brüel & Kjær Technical Review No.4, 1976.

9. UPTON, R. Automated Measurements of Reverberation Time Using the Digital Frequency Analyzer Type 2131, p.3.
Brüel & Kjær Technical Review No.2, 1977
10. LARSEN, H. Article will be published in Brüel & Kjær Technical Review No.4-1978
11. BRUEL, PER V. Sound Insulation and Room Acoustics, Chapter 3
Chapman & Hall
12. ASHLEY, C.M. Determination of Sound Power using a Reverberant Room. ASHRAE 71st Annual Meeting in Cleveland, Ohio, June-July 1964

PREVIOUSLY ISSUED NUMBERS OF BRÜEL & KJÆR TECHNICAL REVIEW

(Continued from cover page 2)

- 3-1974 Acoustical Investigation of an Impact Drill.
Measurement of the Dynamic Mass of the Hand-arm System.
- 2-1974 On Signal/Noise Ratio of Tape Recorders.
On the Operating Performance of the Tape Recorder Type 7003 in a Vibrating Environment.
- 1-1974 Measurements of averaging times of Level Recorders Types 2305 and 2307.
A simple Equipment for direct Measurement of Reverberation Time using Level Recorder Type 2305.
Influence of Sunbeams striking the Diaphragms of Measuring Microphones.
- 4-1973 Laboratory tests of the Dynamic Performance of a Turbocharger Rotor-Bearing System.
Measurements on the Resonance Frequencies of a Turbocharger Rotor.

SPECIAL TECHNICAL LITERATURE

As shown on the back cover page Brüel & Kjær publish a variety of technical literature which can be obtained from your local B&K representative.

The following literature is presently available:

- Mechanical Vibration and Shock Measurements
(English, German, Russian)
- Acoustic Noise Measurements (English, Russian), 2. edition
- Strain Measurements
- Frequency Analysis (English)
- Electroacoustic Measurements
(English, German, French, Spanish)
- Catalogs (several languages)
- Product Data Sheets (English, German, French, Russian)

Furthermore, back copies of the Technical Review can be supplied as shown in the list above. Older issues may be obtained provided they are still in stock.

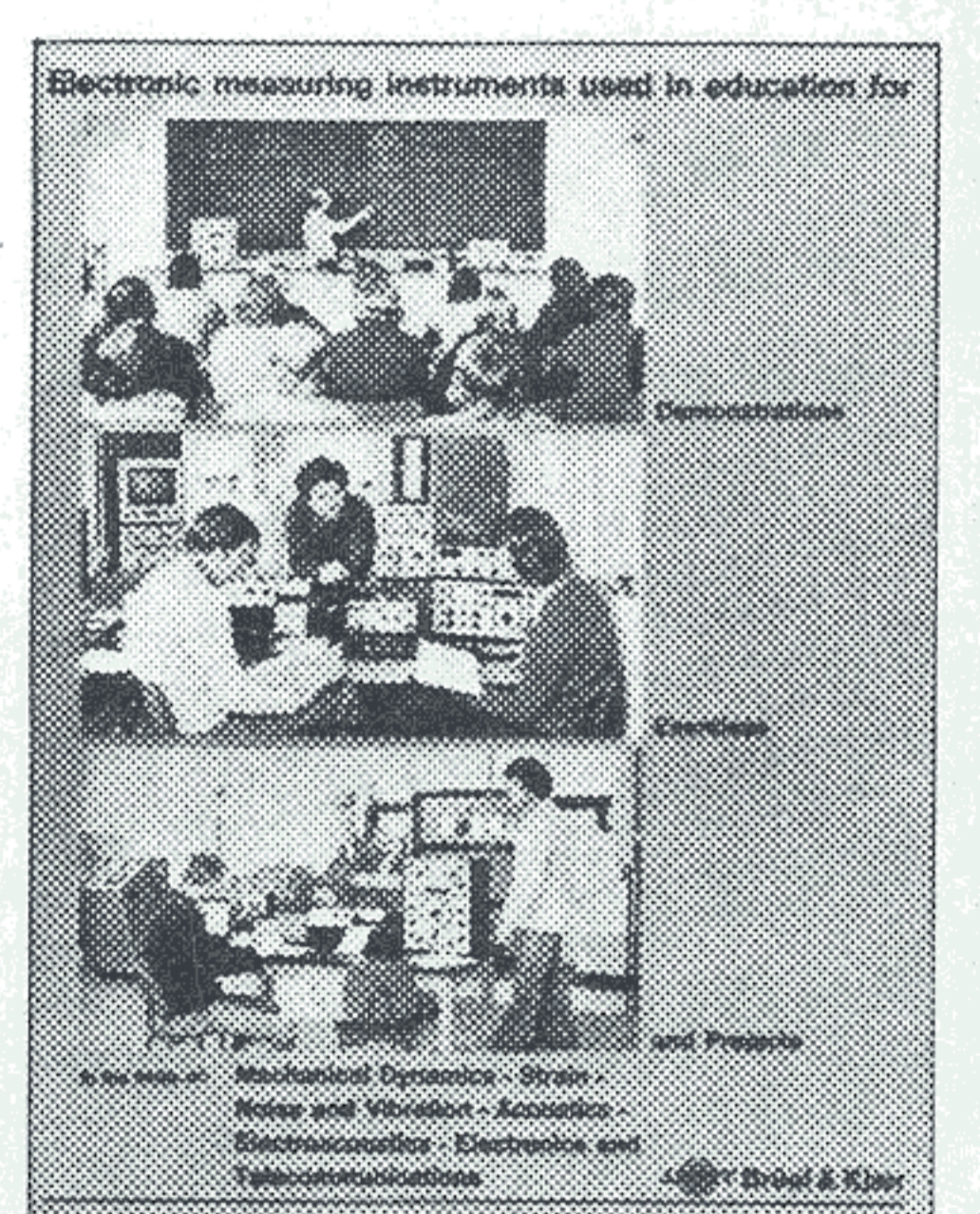
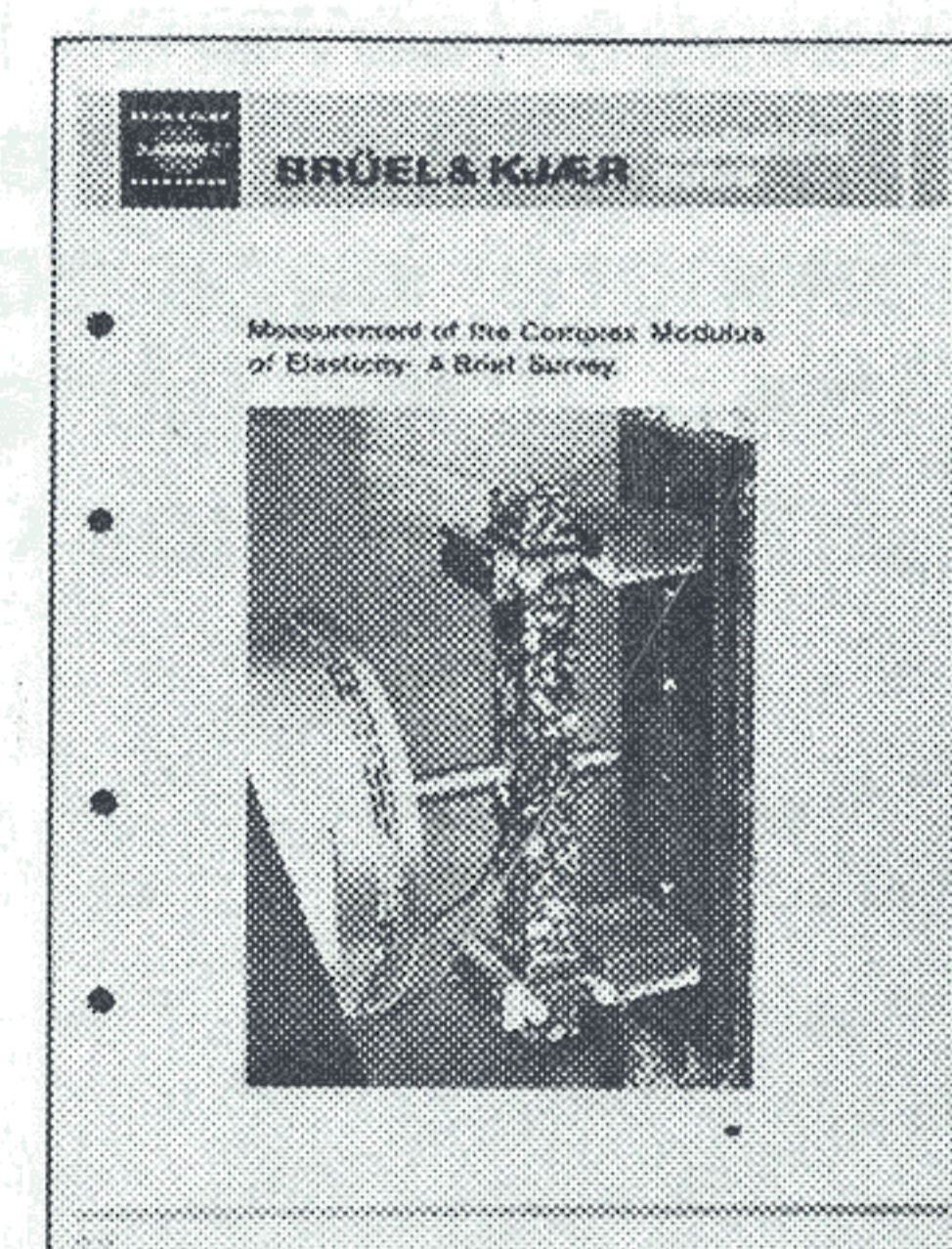
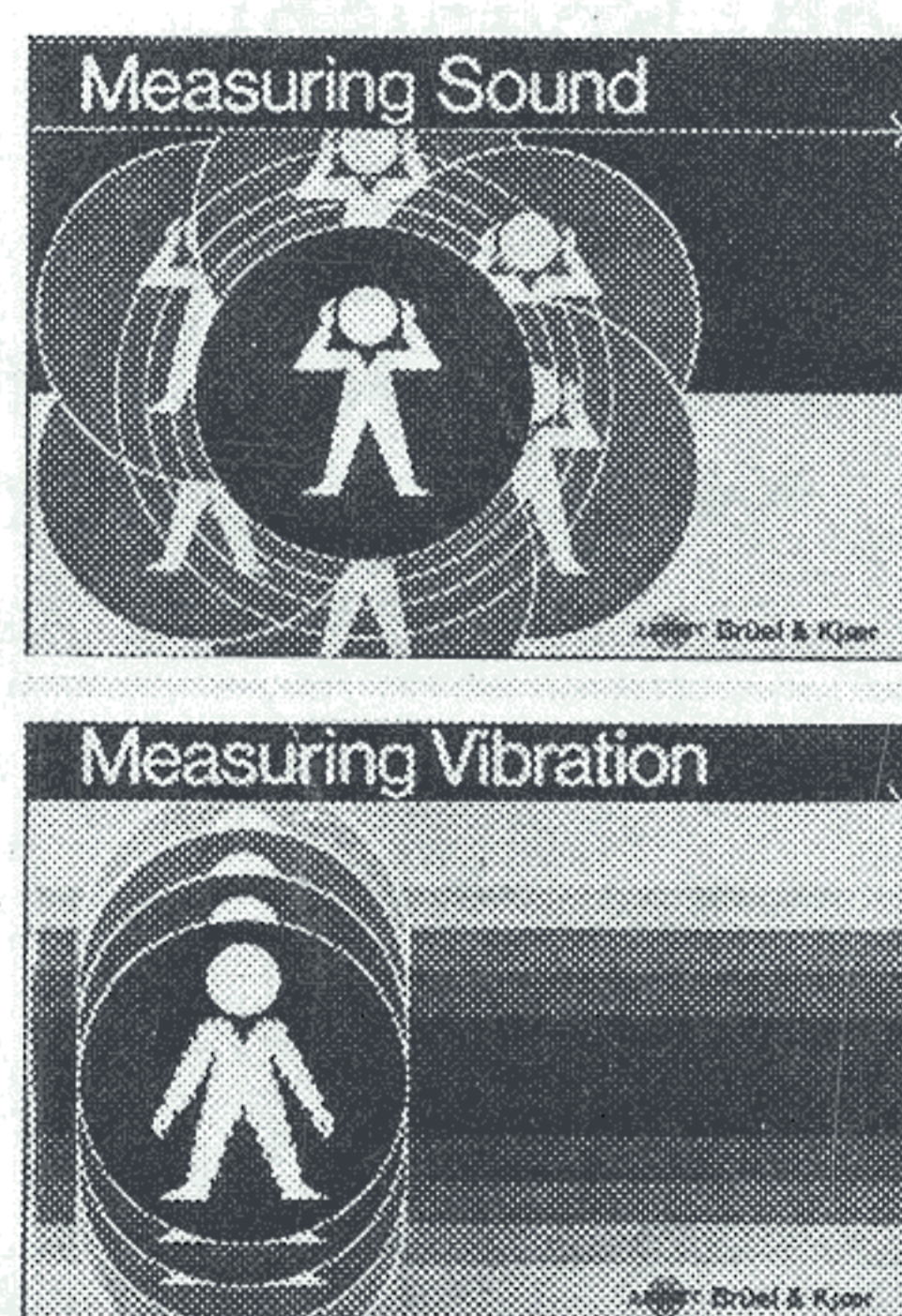
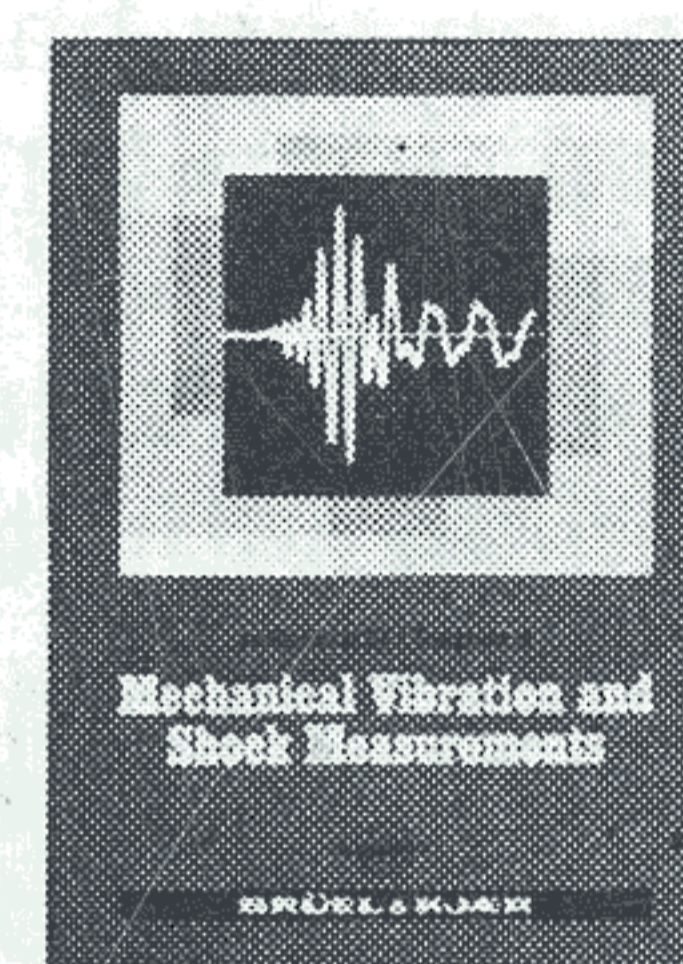
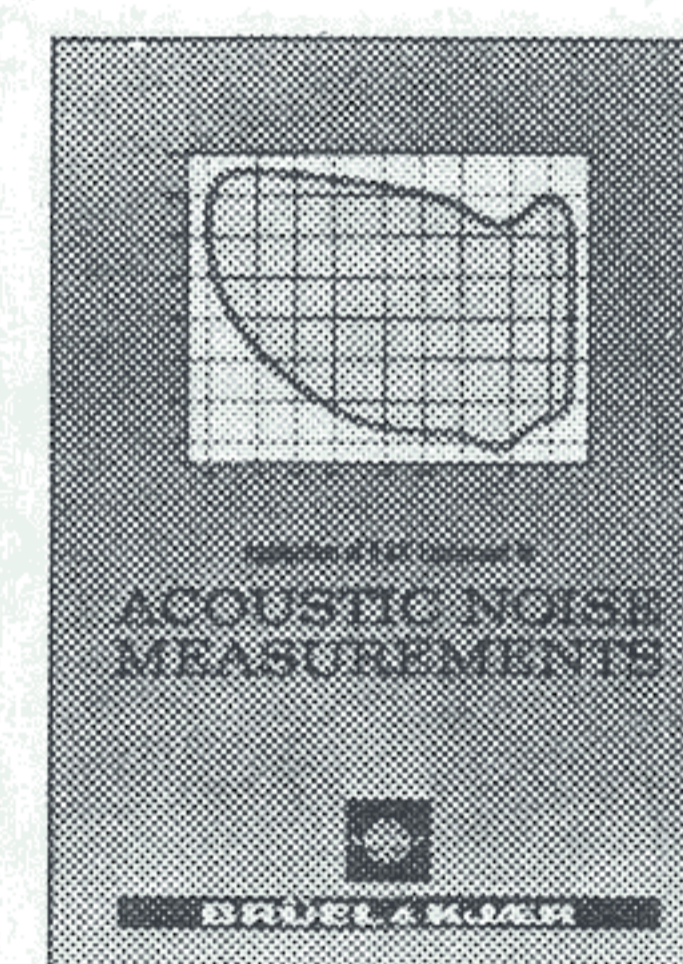
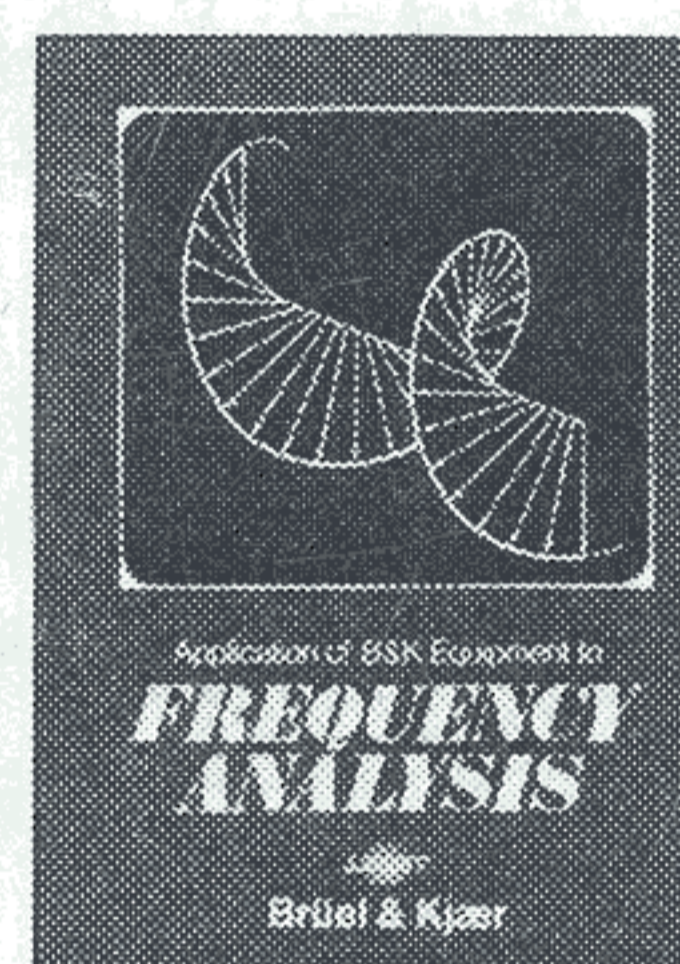
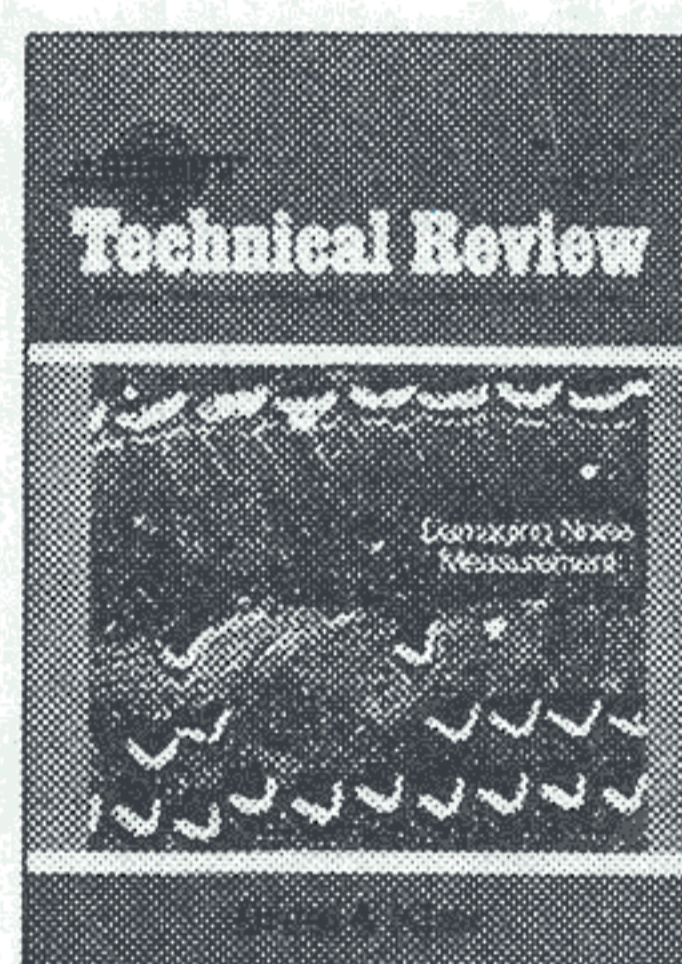
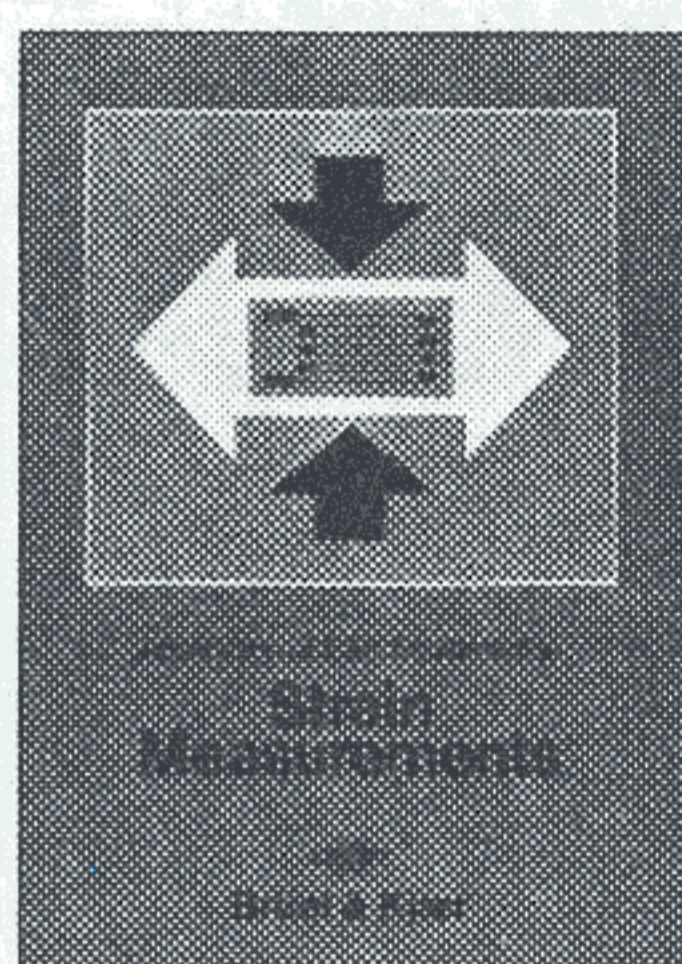
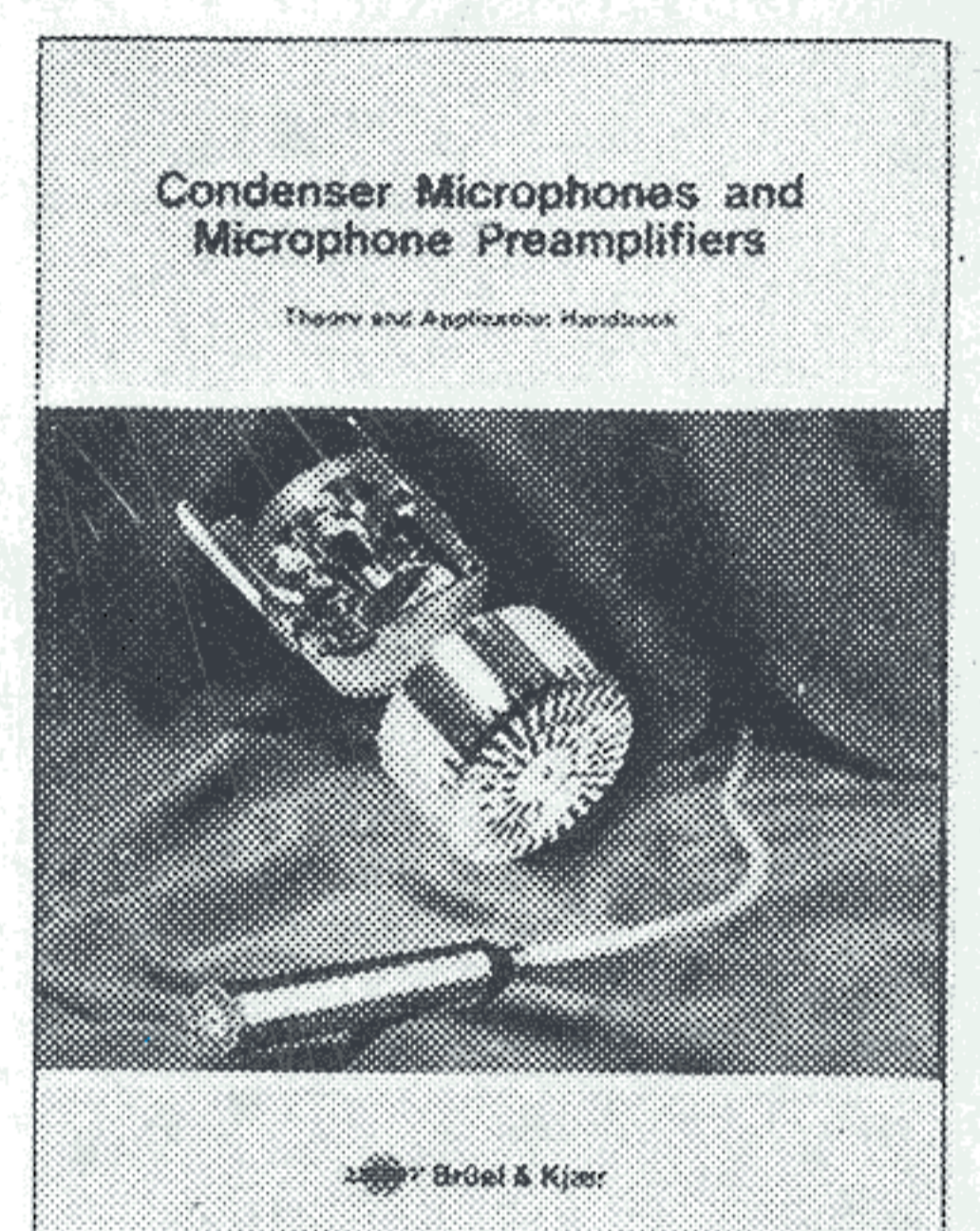
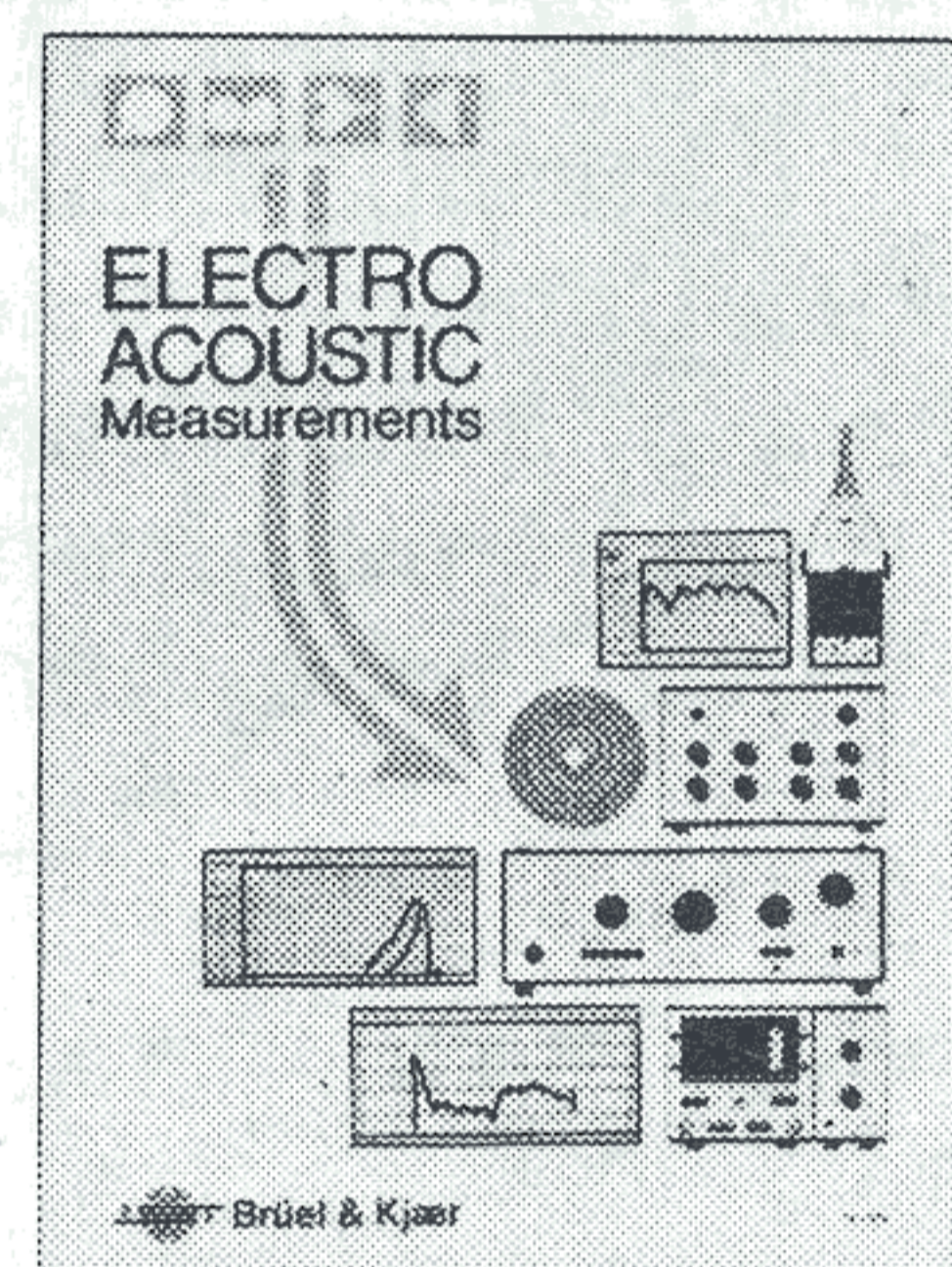
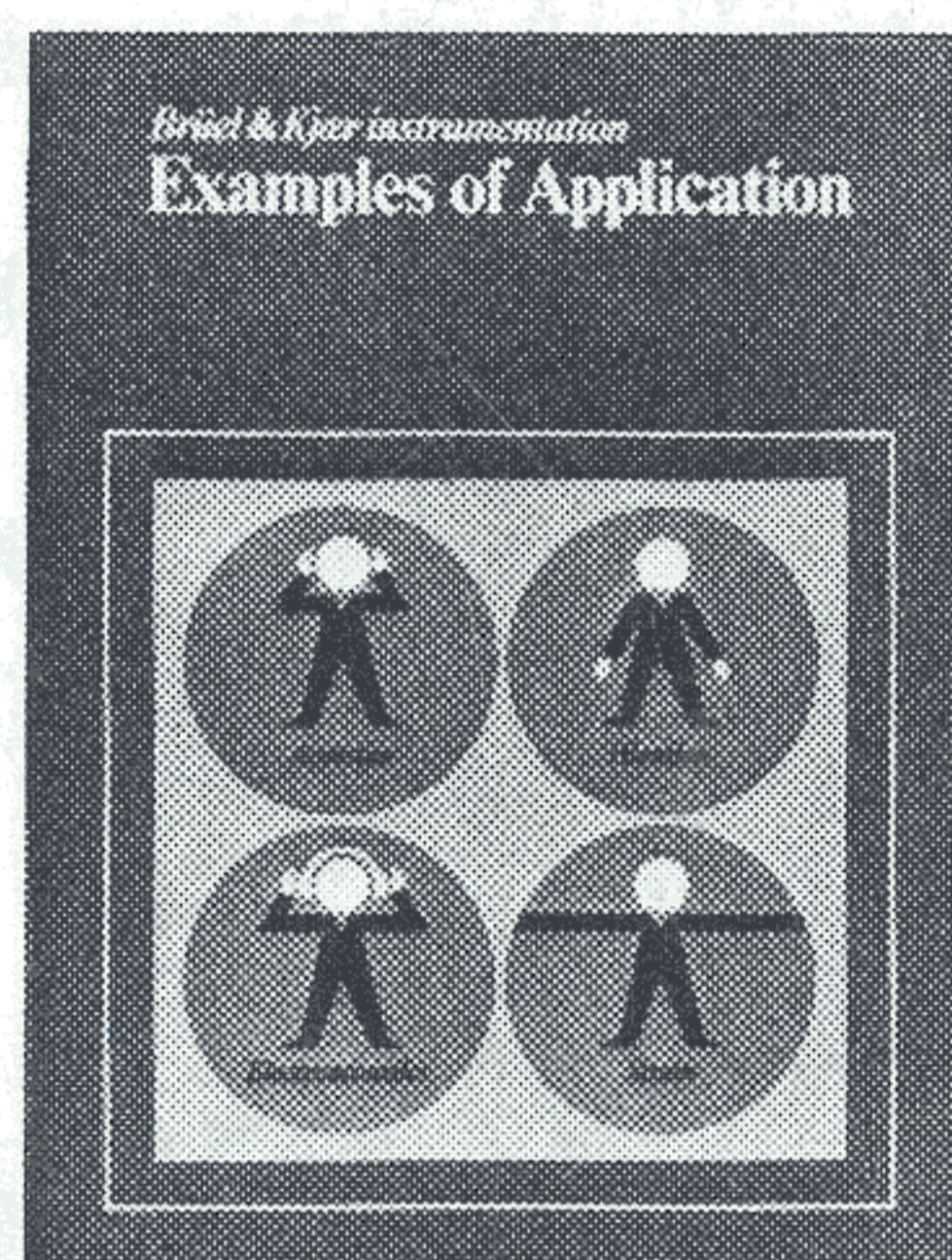
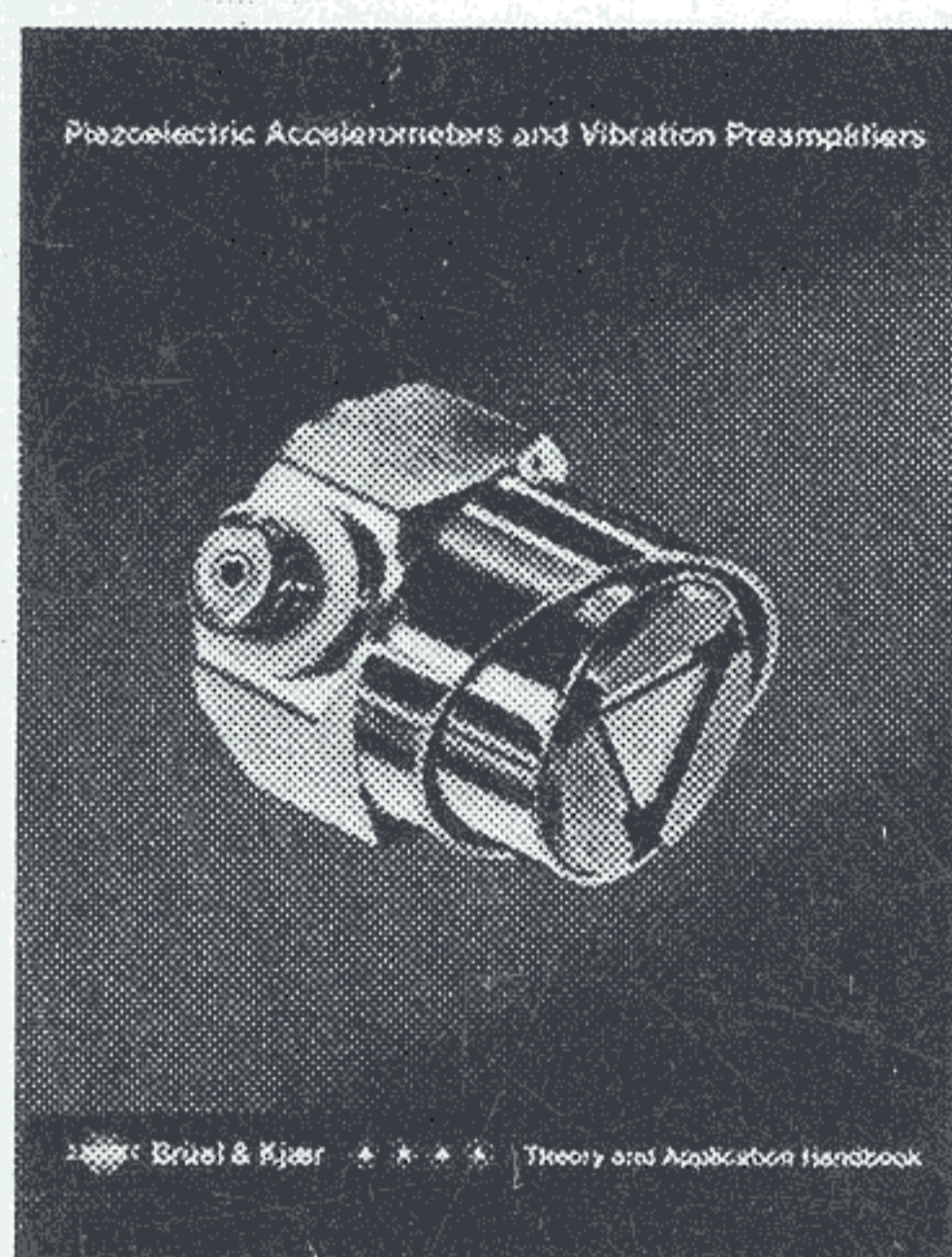

Brüel & Kjær

DK-2850 NÆRUM, DENMARK • Telephone: + 45 2 80 05 00 • Telex: 37316 bruks dk